

8774339COM Hall Tree

**NOV
OGR
ATZ**

Date of Purchase ___ / ___ / ___
Lot Number:

B348774339COM0

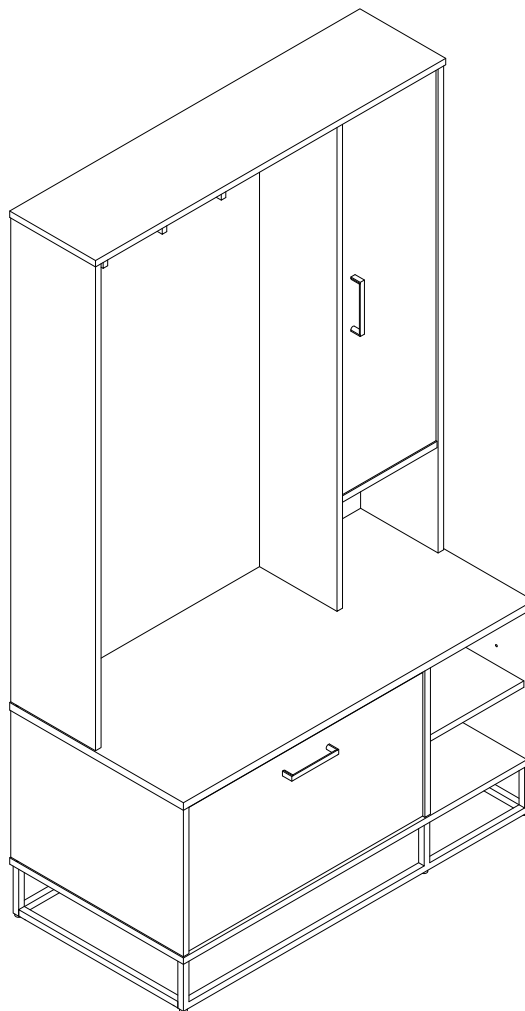

Do Not Return This Product!

Contact our customer service team for help first.

Call: 1-800-489-3351 (toll free)

Visit: www.ameriwoodhome.com

THIS INSTRUCTION BOOKLET CONTAINS **IMPORTANT** SAFETY INFORMATION. PLEASE READ AND KEEP FOR FUTURE REFERENCE.

Secure Your Furniture

Keep your home and family safe with the wall anchor kit that is included with the product.

Serious or fatal crushing injuries can occur from tipping furniture.

WARNING: Manufacturer assumes no liability for improper installation or excessive loads placed on screws or bracket. This wall anchor is not a substitute for proper adult supervision.

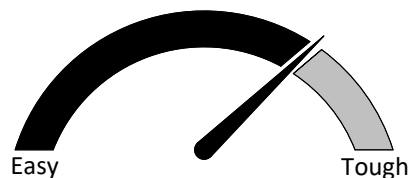

Assembly Difficulty Meter

Follow Ameriwood Home



Contact Us!

Do NOT return this product!

Contact our friendly customer service team first for help.

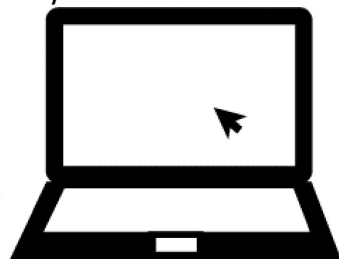
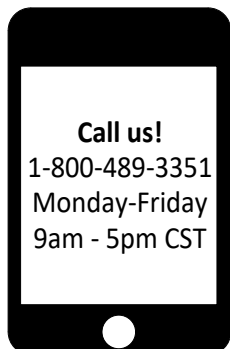

Visit ameriwoodhome.com to view the limited warranty valid in the U.S. and Canada.

Assembly Tips



Helpful Hints

PEOPLE NEEDED FOR ASSEMBLY: **2**
ESTIMATED ASSEMBLY TIME: **1 HOUR**

- Open your item in the area you plan to keep it to avoid excessive heavy lifting.
- Identify, sort and count the parts before attempting assembly.
- Compression dowels are lightly tapped in with a hammer.
- Slides are labeled with a **R** (right) and **L** (left) for proper placement.
- Make sure to always face the point on the top of the Cam Lock towards the outer edge.
- Use all the nails provided for the back panel and spread them out equally.
- Back panel must be used to make sure your unit is sturdy.
- Do NOT use harsh chemicals or abrasive cleaners on this item.
- Never push, pull, or drag your furniture.

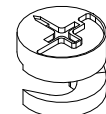

Before You Start

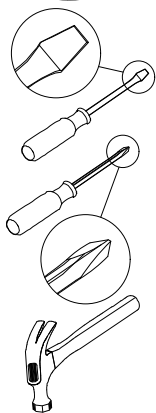
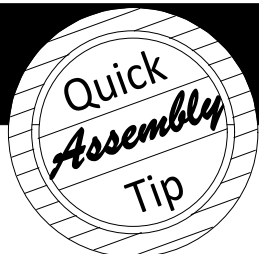

- ✓ Read through each step carefully and follow the proper order
- ✓ Separate and count all your parts and hardware
- ✓ Give yourself enough room for the assembly process
- ✓ Have the following tools: Flat Head Screwdriver, #2 Phillips Head Screwdriver and Hammer
- ✓ Caution: If using a power drill or power screwdriver for screwing, please be aware to slow down and stop when screw is tight. Failure to do so may result in stripping the screw.

Cam Lock Fastening System

This Cam Lock Fastening System will be used throughout the assembly process.

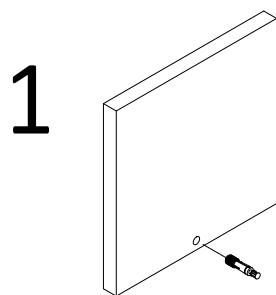

1 Press CAM BOLT into hole.

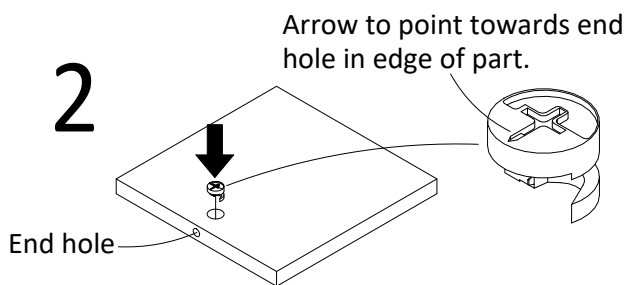

2 Press CAM LOCK into hole.

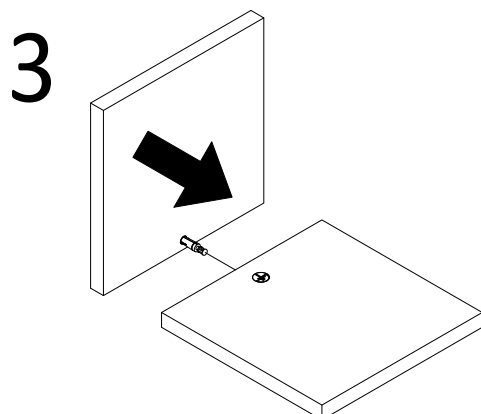

3 Press parts together so CAM BOLT inserts into edge hole.

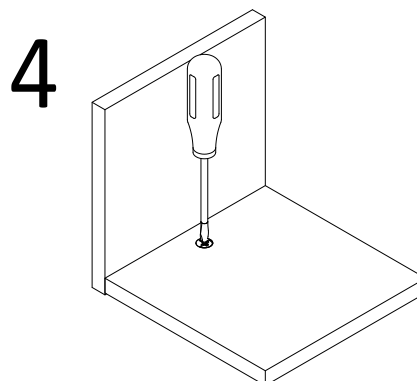

4 Using a screwdriver, turn the CAM LOCK clockwise to lock the CAM LOCK and CAM BOLT into their holes and fastening parts together.

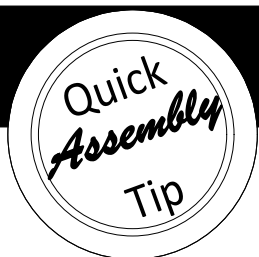

Before You Start

Please Note:
You may need to lightly tap the wood dowels to insert into the holes during your assembly process.

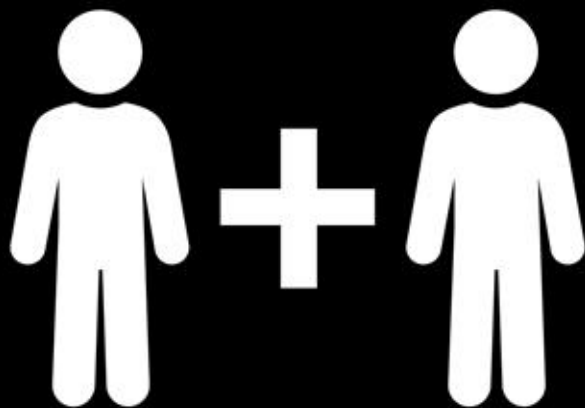
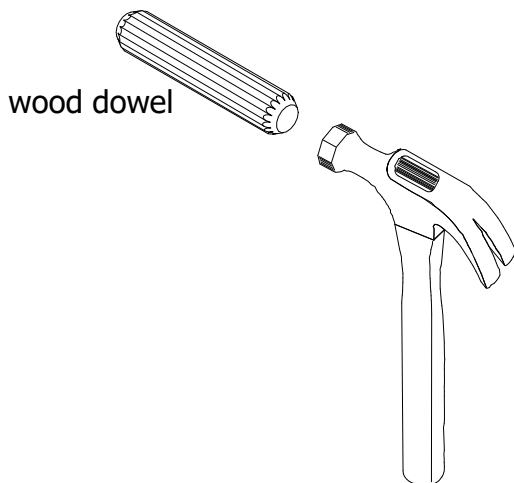

2 PEOPLE NEEDED FOR ASSEMBLY

**2 PERSONAS NECESITADAS
PARA LA ASAMBLEA**

**2 PERSONNES NÉCESSAIRES
POUR L'ASSEMBLAGE**

CAUTION: Failure to use 2 people for assembly could result in unit damage or personal injury.

PRECAUCIÓN: Si no se utilizan 2 personas para el ensamblaje, se pueden producir daños en la unidad o lesiones personales.

ATTENTION: Échec d'utiliser 2 personnes pour l'assemblage peut causer du dommage au meuble ou causer des blessures.

Board Identification

Not actual size

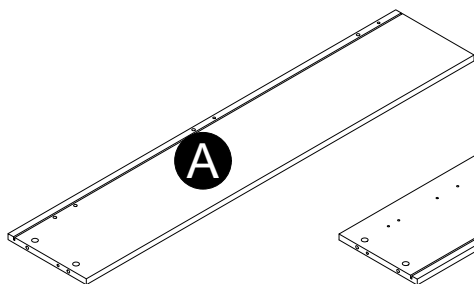

Upper Left Panel
38774339010

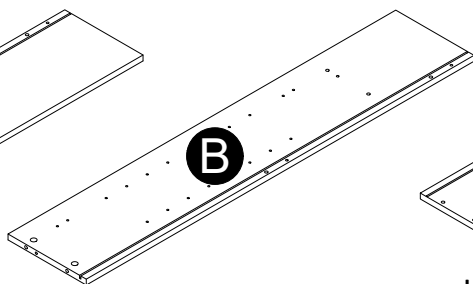

Upper Right Panel
38774339020

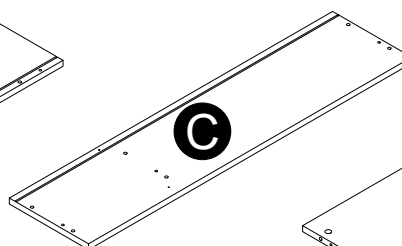

Upper Top
38774339030

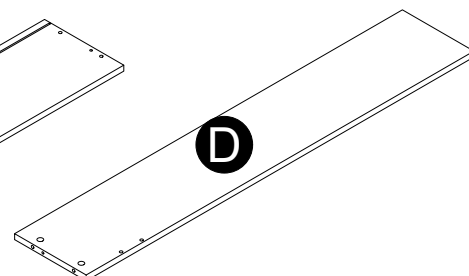

Upper Partition
38774339040

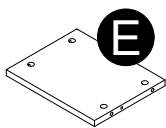

Upper Right Shelf
38774339050

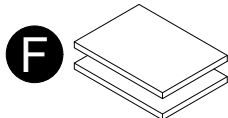

Upper Adjustable
Shelf (x2)
38774339060

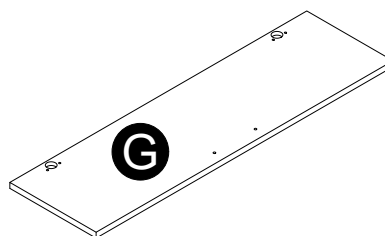

Door
38774339070

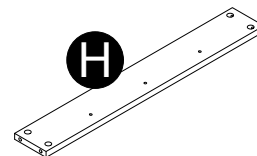

Hook Panel
38774339080

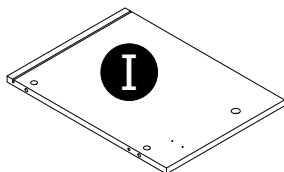

Lower Left Panel
38774339090

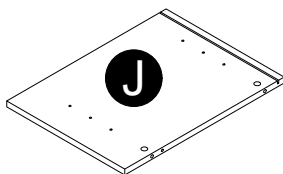

Lower Right Panel
38774339100

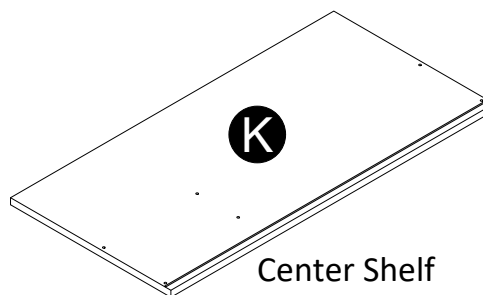

Center Shelf
38774339110

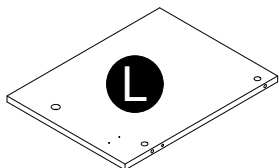

Lower Partition
38774339120

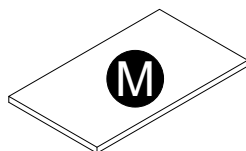

Lower Adjustable Shelf
38774339130

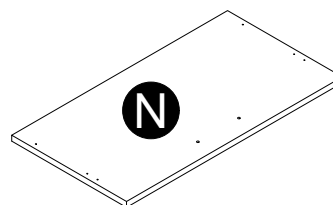

Storage Door
38774339140

Board Identification

Not actual size

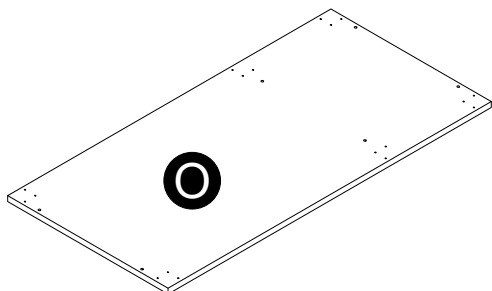

Bottom
38774339150

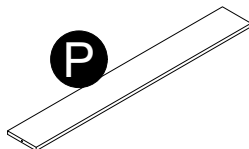

Shoe Storage Bottom
38774339160

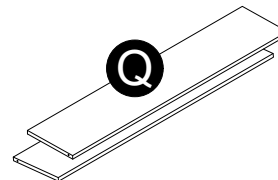

Shoe Storage Panel (x2)
38774339170

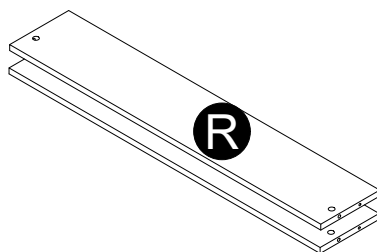

Support (x2)
38774000180

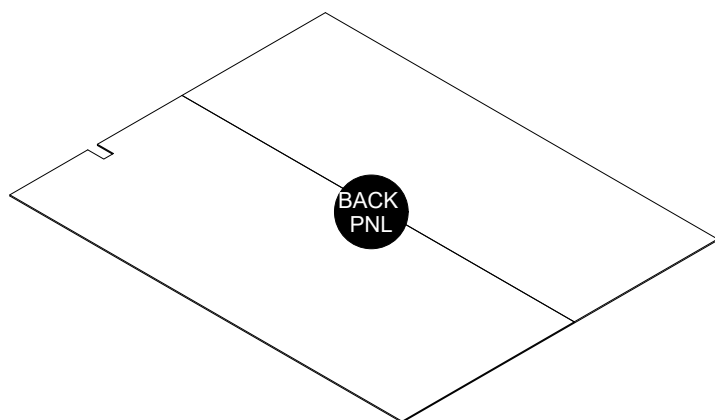

Upper Back Panel
K877433900

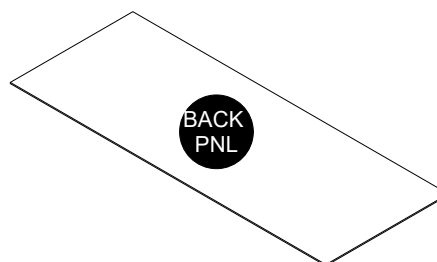

Lower Back Panel
K877433910

These pieces are paperboard construction.
They are not made from wood, but are
required for the assembly of your unit.

Board Identification

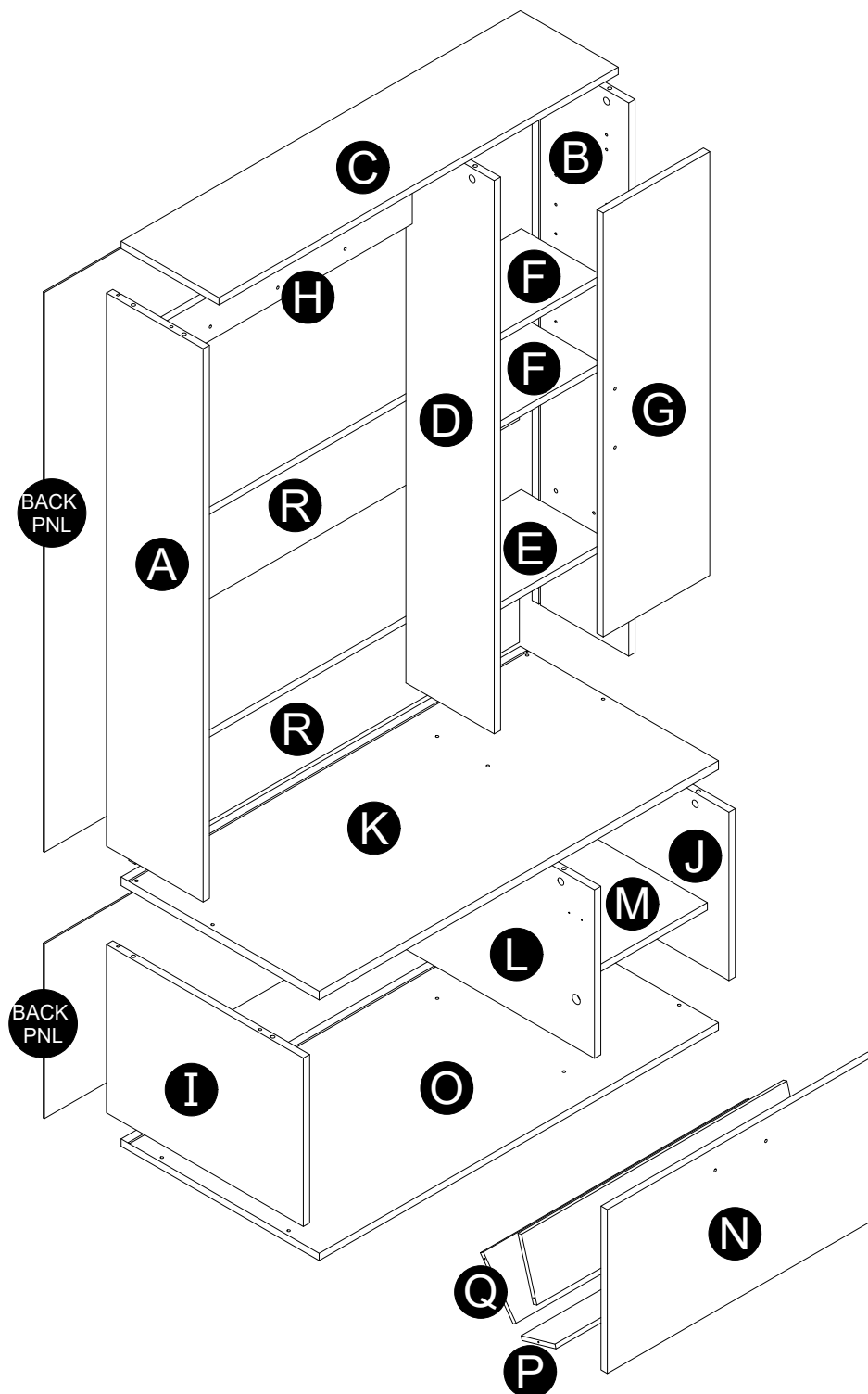

Part List

Actual Size

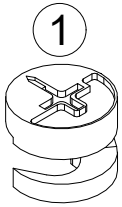

(x24)
#A22700
cam lock

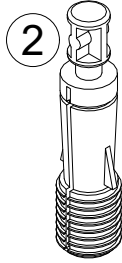

(x24)
#A22710
cam bolt

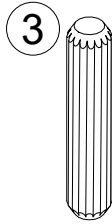

(x12)
#A21670
wood dowel

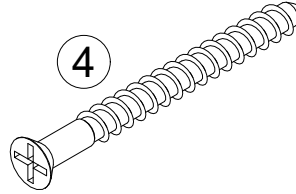

(x12)
#A23030
confirmat



(18)
#A14220
screw

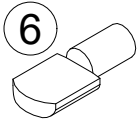

(x12)
#A80250
shelf support

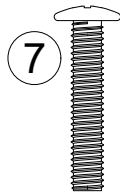

(x7)
#A17400
7/8" bolt



(x11)
#A11170
5/8" pan head

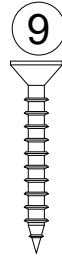

(x6)
#A11310
7/8" flat head

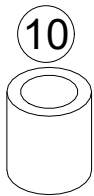

(x5)
#A89020
plastic stop

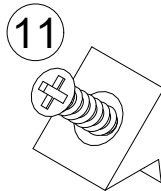

(x8)
#A54710
wedge

Part List

Not Actual Size

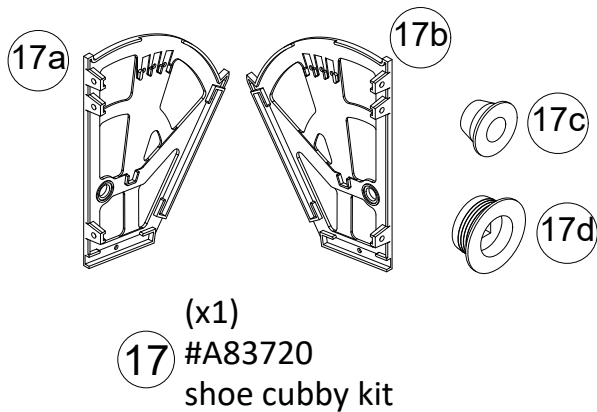
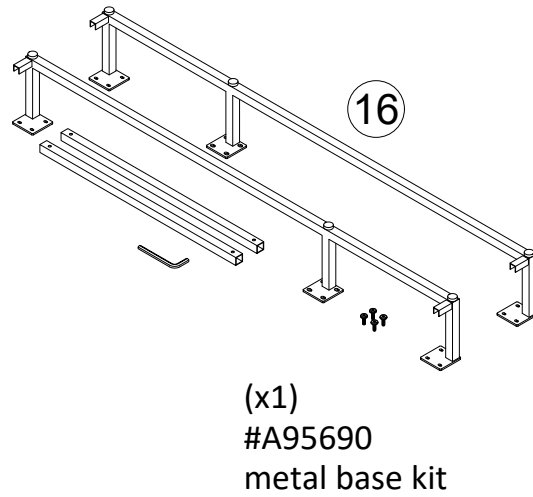
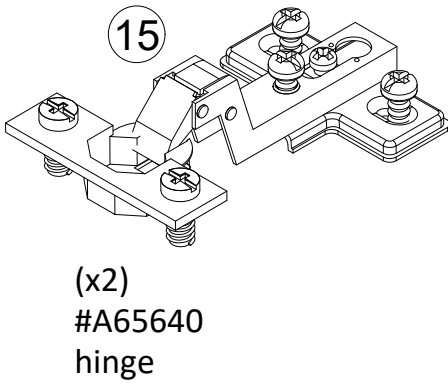
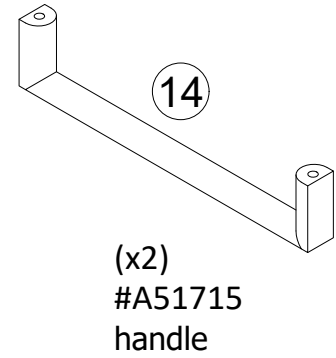
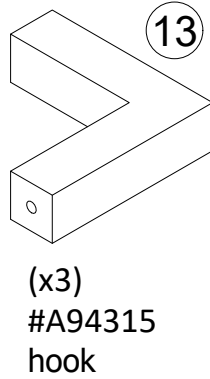
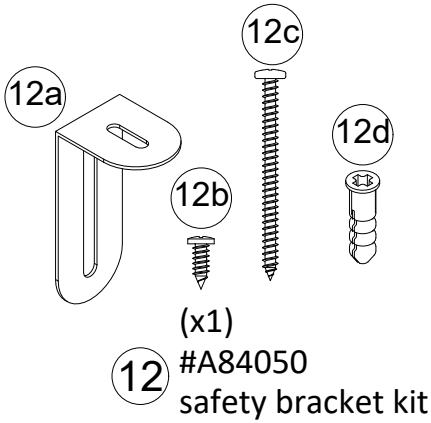

STEP 1

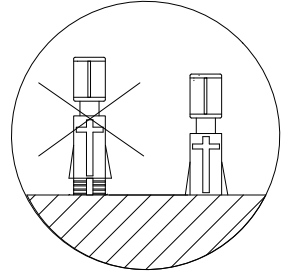
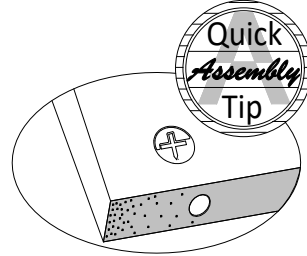
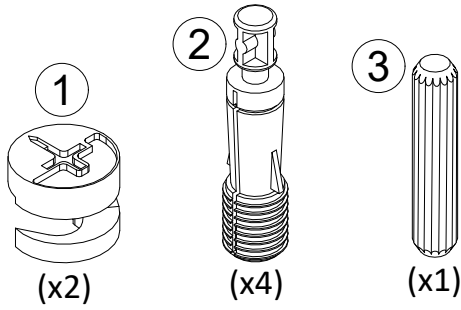

Proper orientation of CAM LOCK

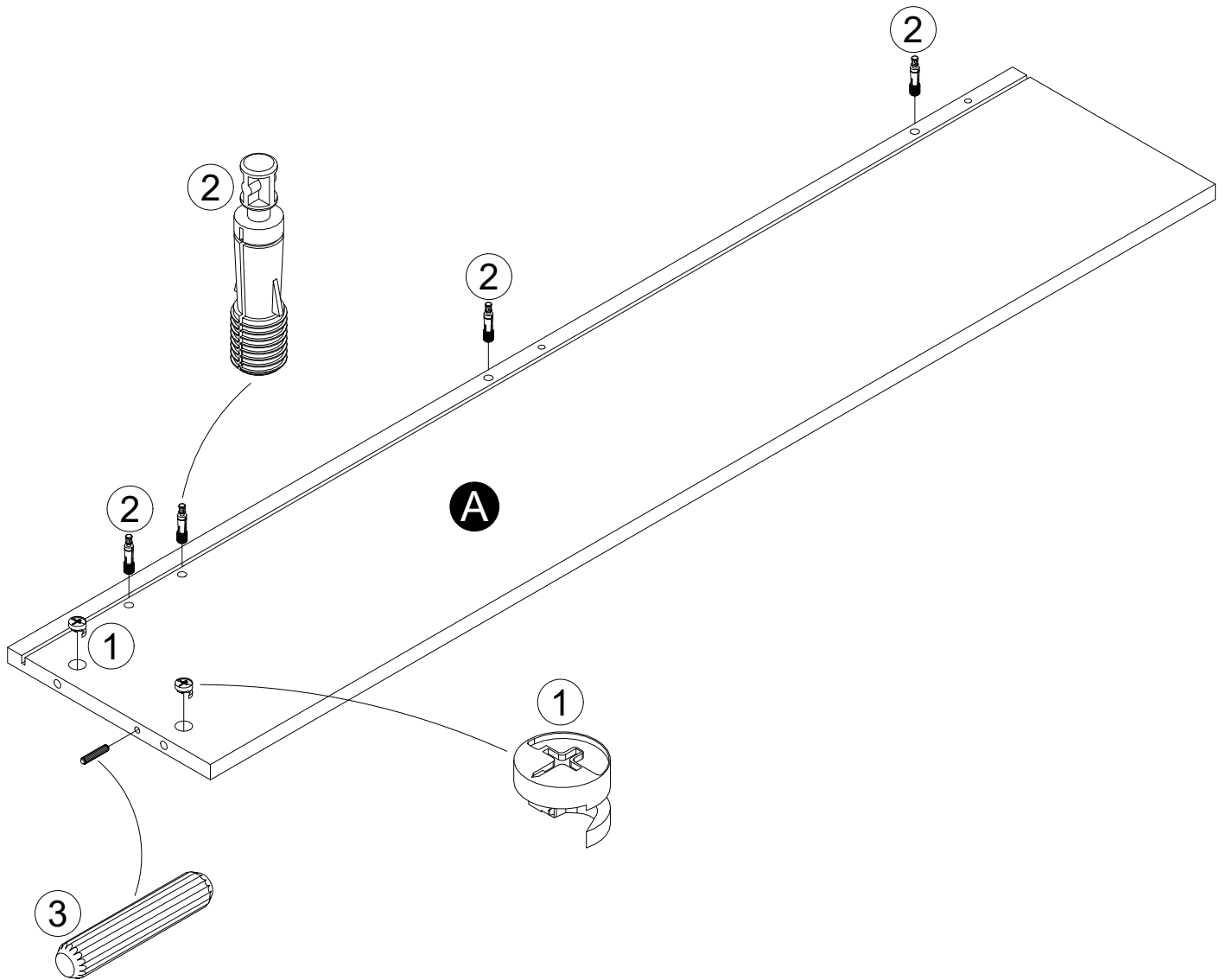

STEP 2

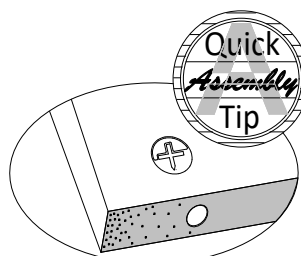
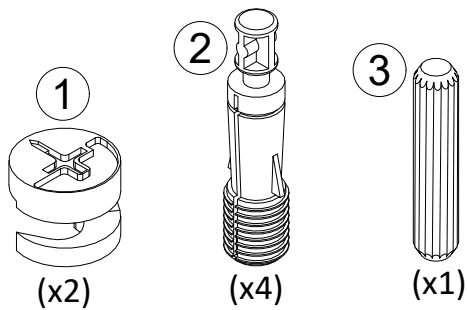

Proper orientation of CAM LOCK

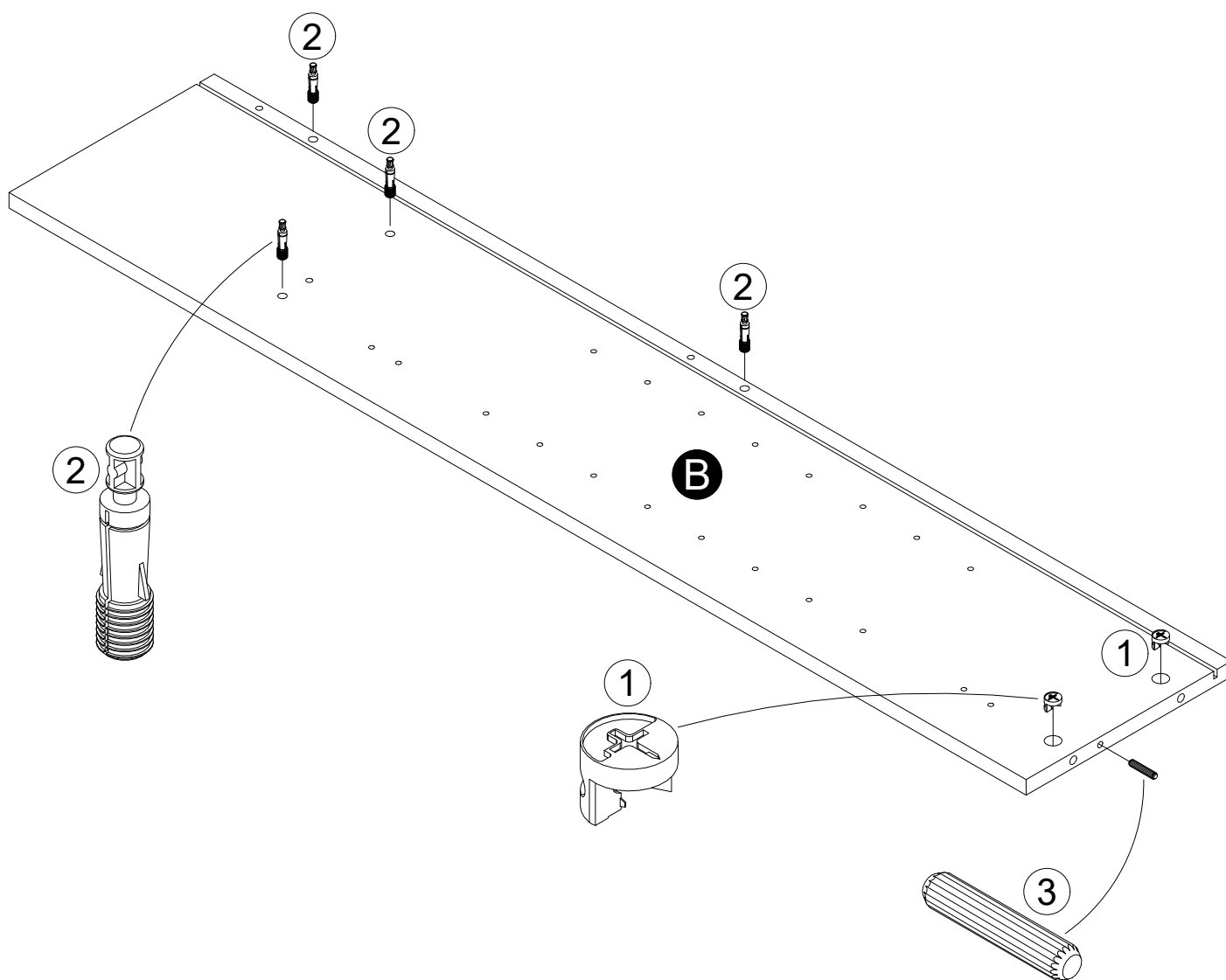
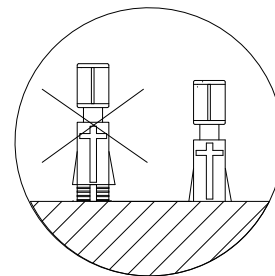

STEP 3

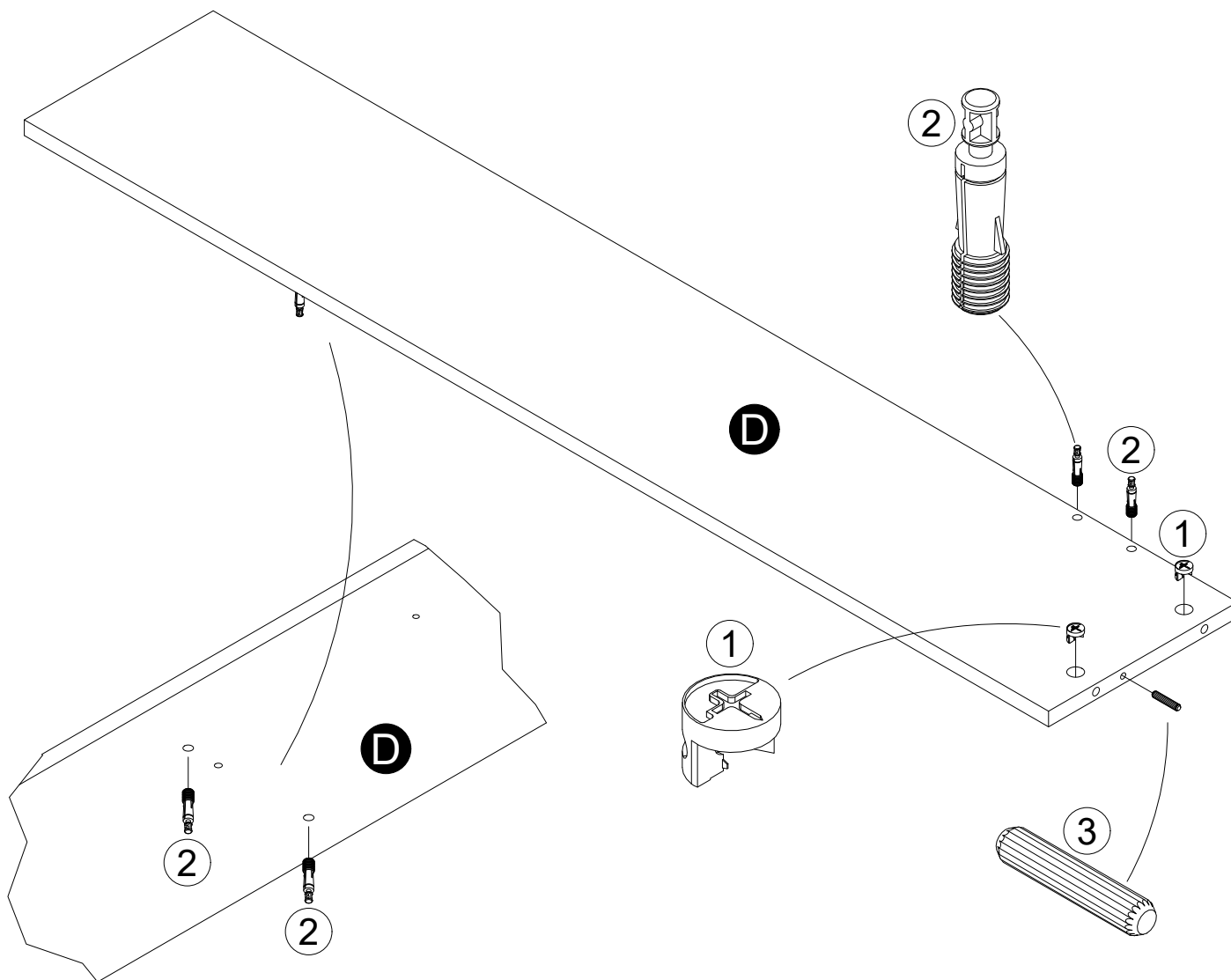
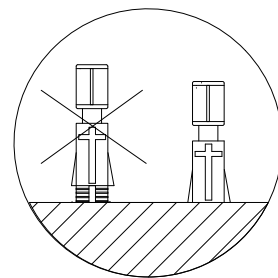
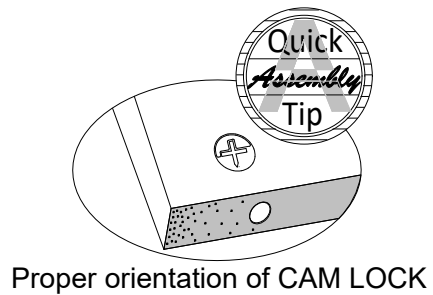
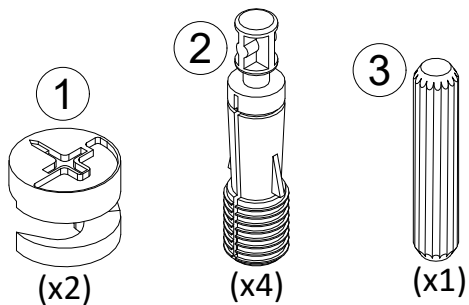

STEP 4

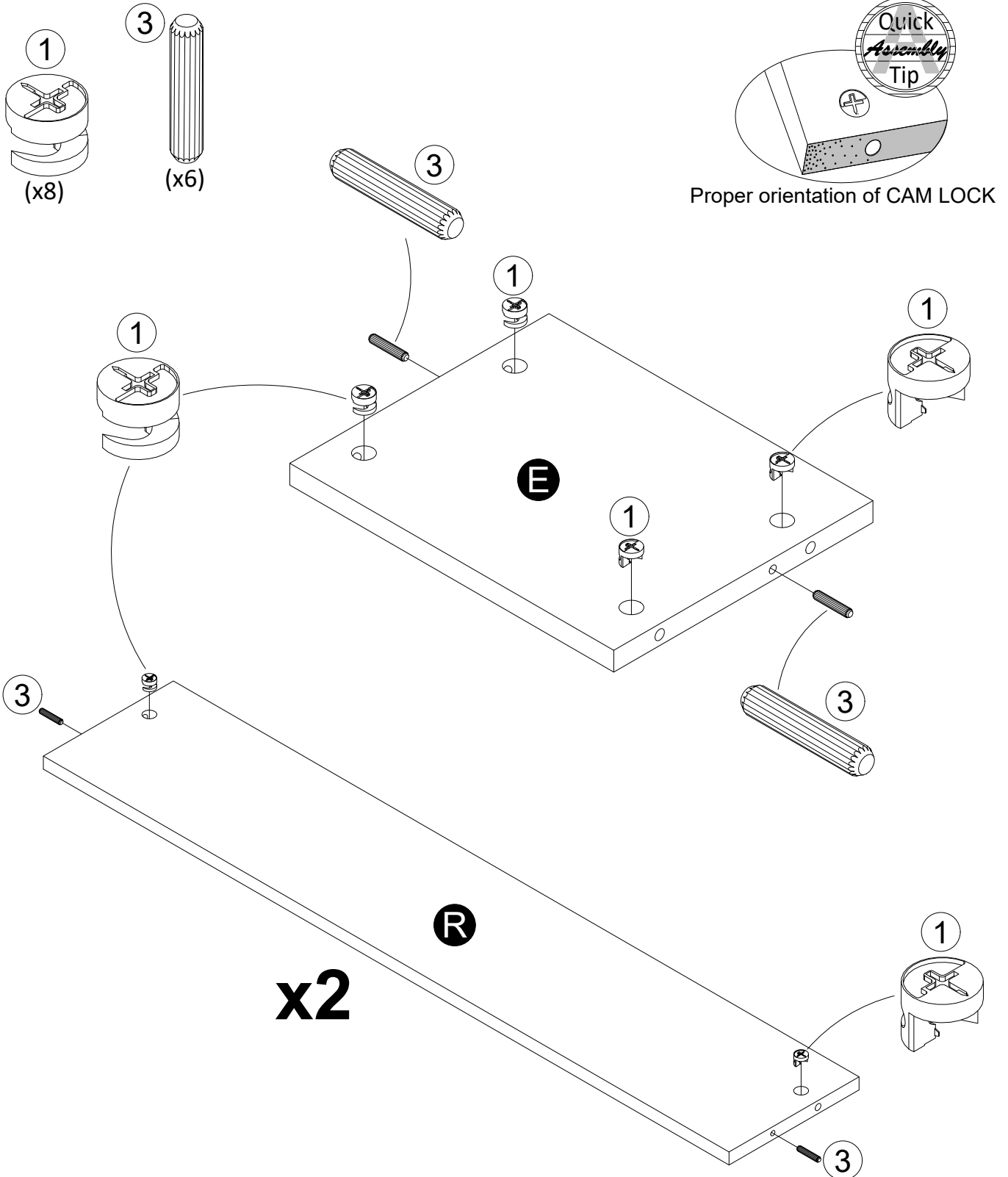

STEP 5

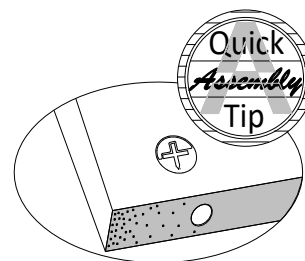
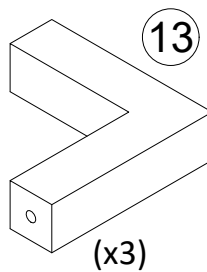
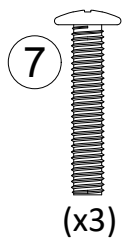
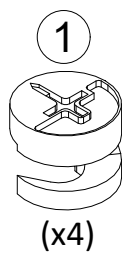
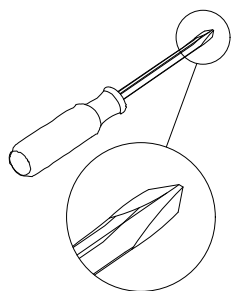

Proper orientation of CAM LOCK

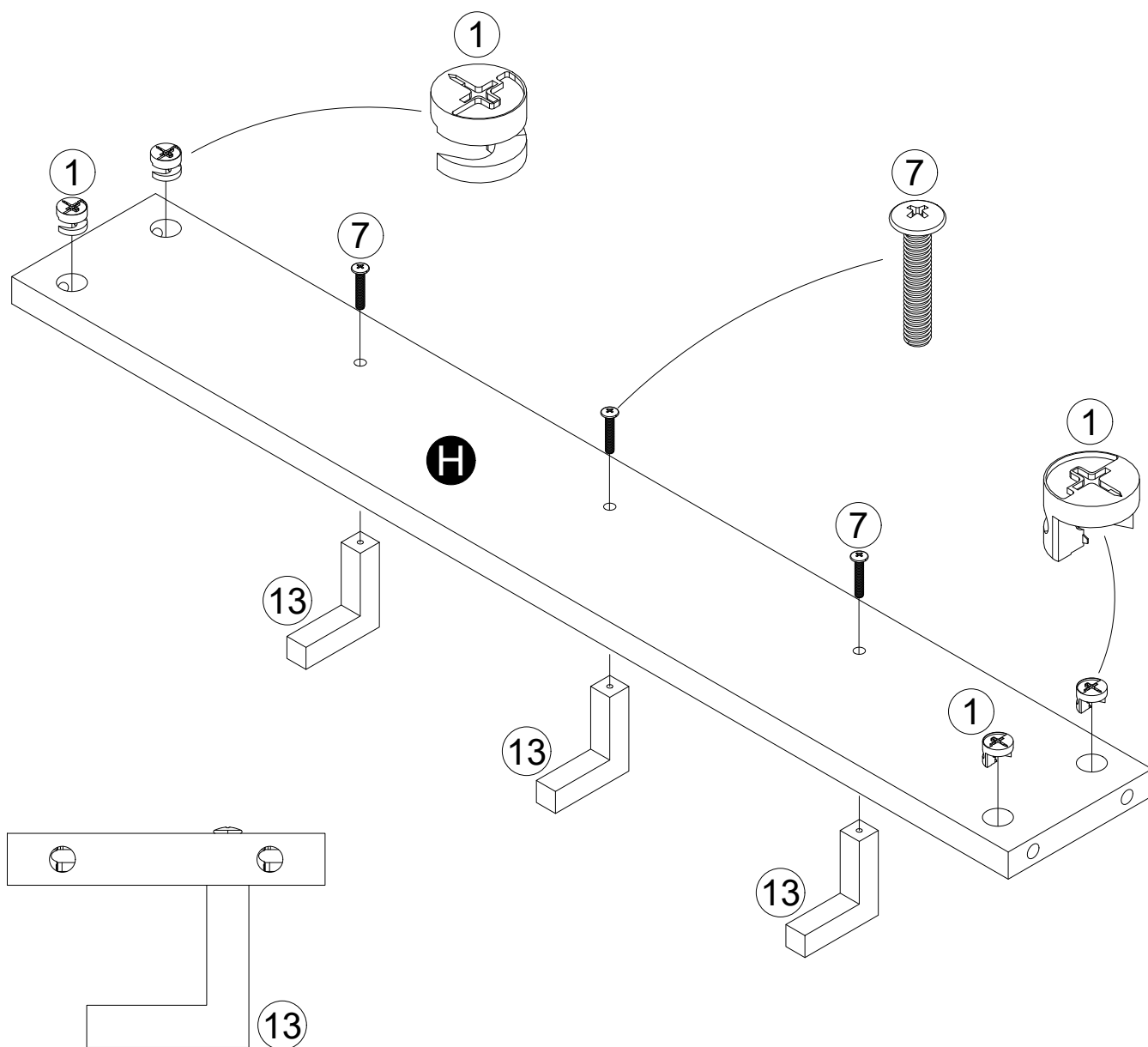

STEP 6

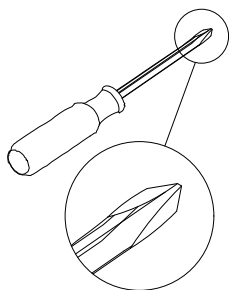

Finished Edges Up

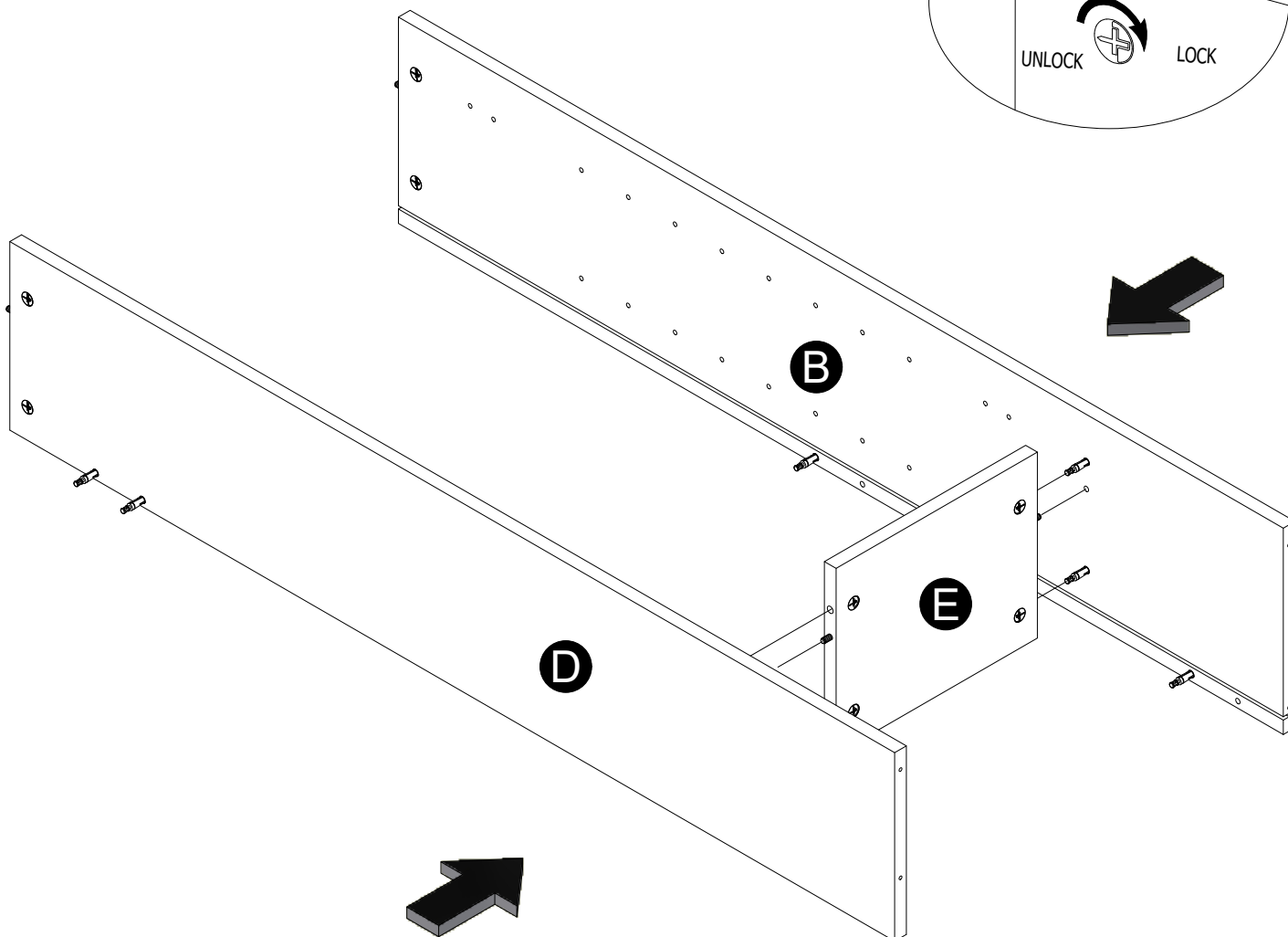
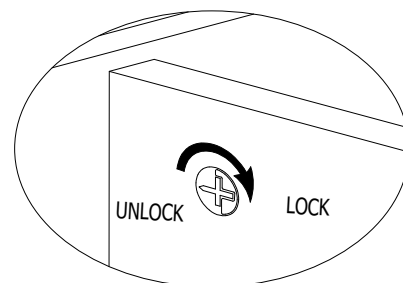

STEP 7

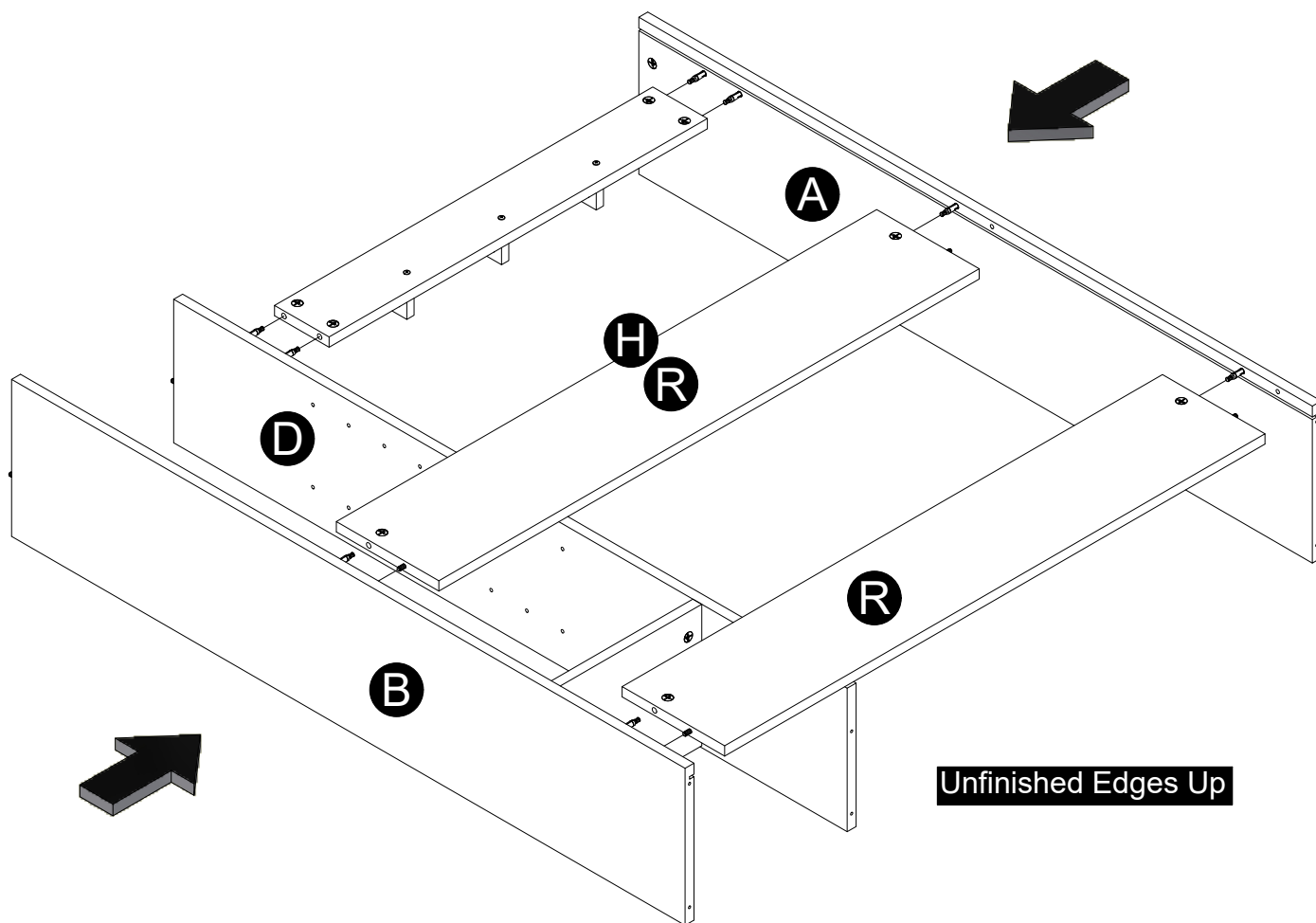
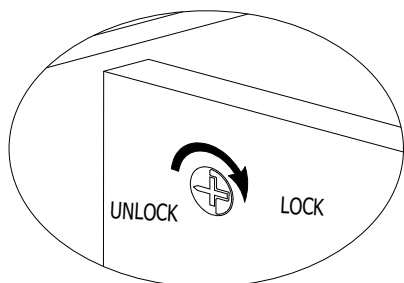
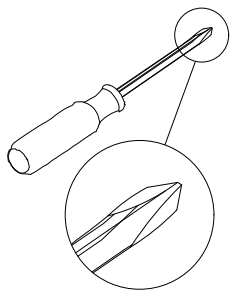

STEP 8

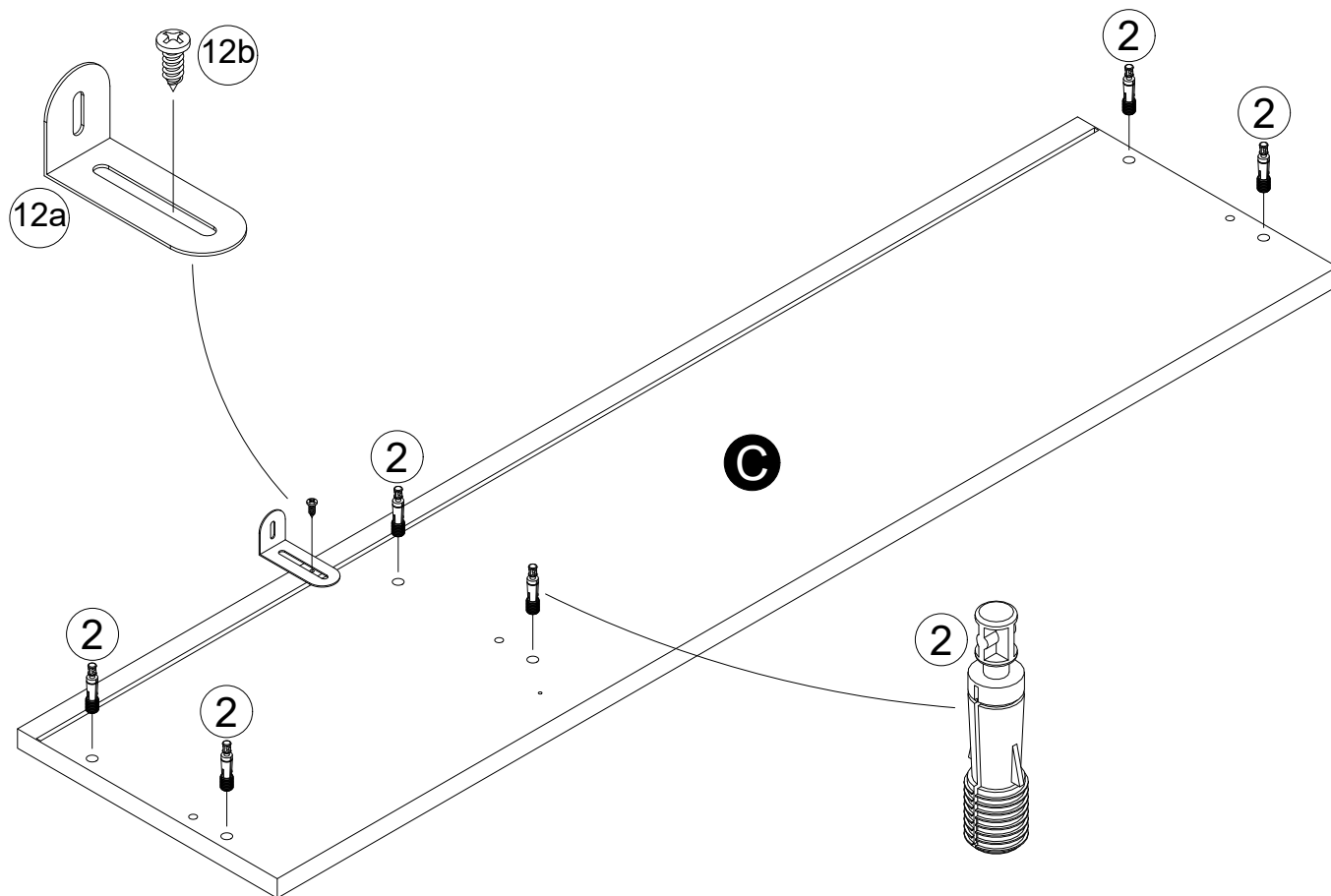
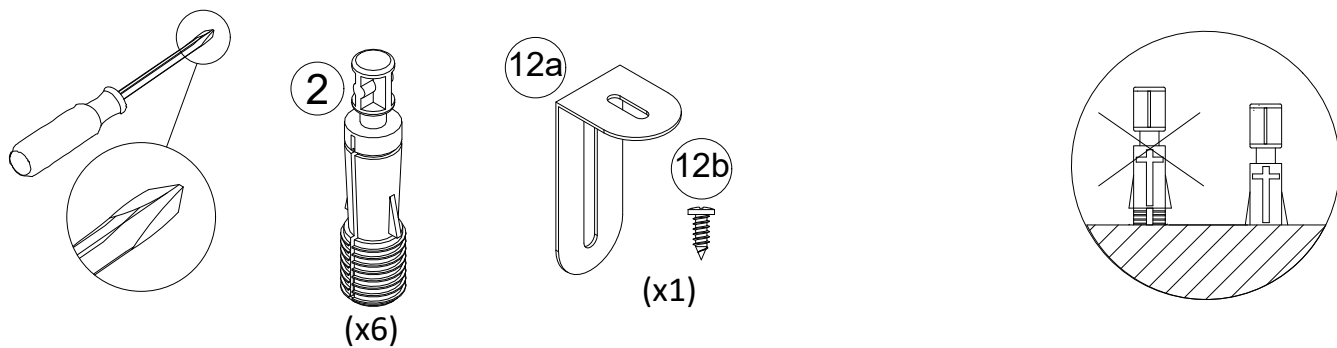

STEP 9

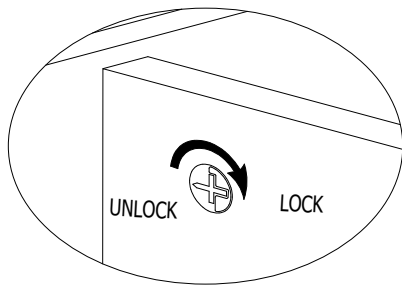
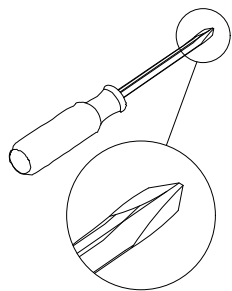

Finished Edges Up

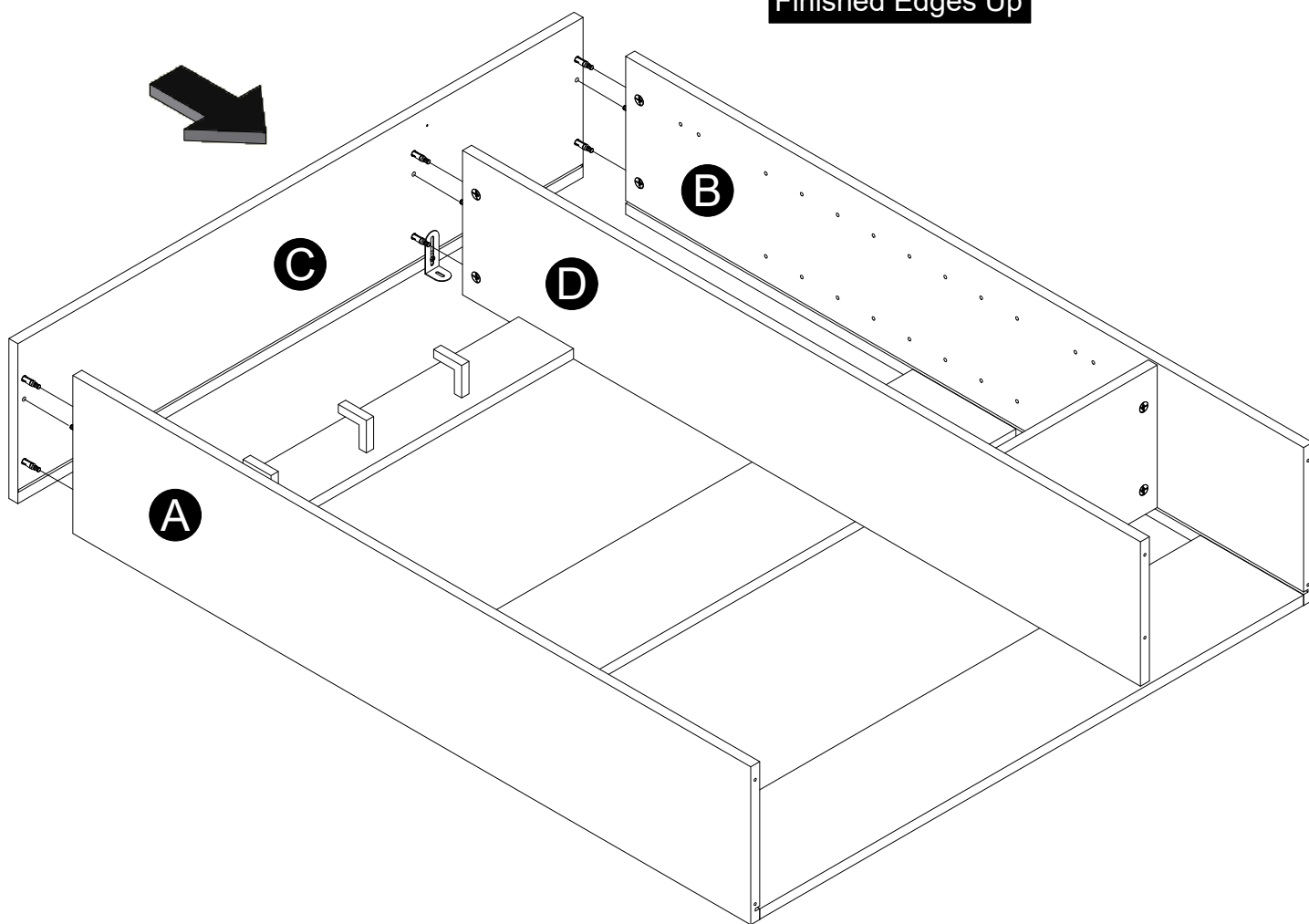

STEP 10

IMPORTANT! THE BACK PANEL IS A STRUCTURAL PART OF THIS UNIT AND MUST BE INSTALLED PROPERLY.

Unfold the back panel. With the finished surface facing up, slide the back panel into the groove in the upper left and upper right panels (A&B) seating into the groove in the top (C). Note, the back panel will be over the supports.

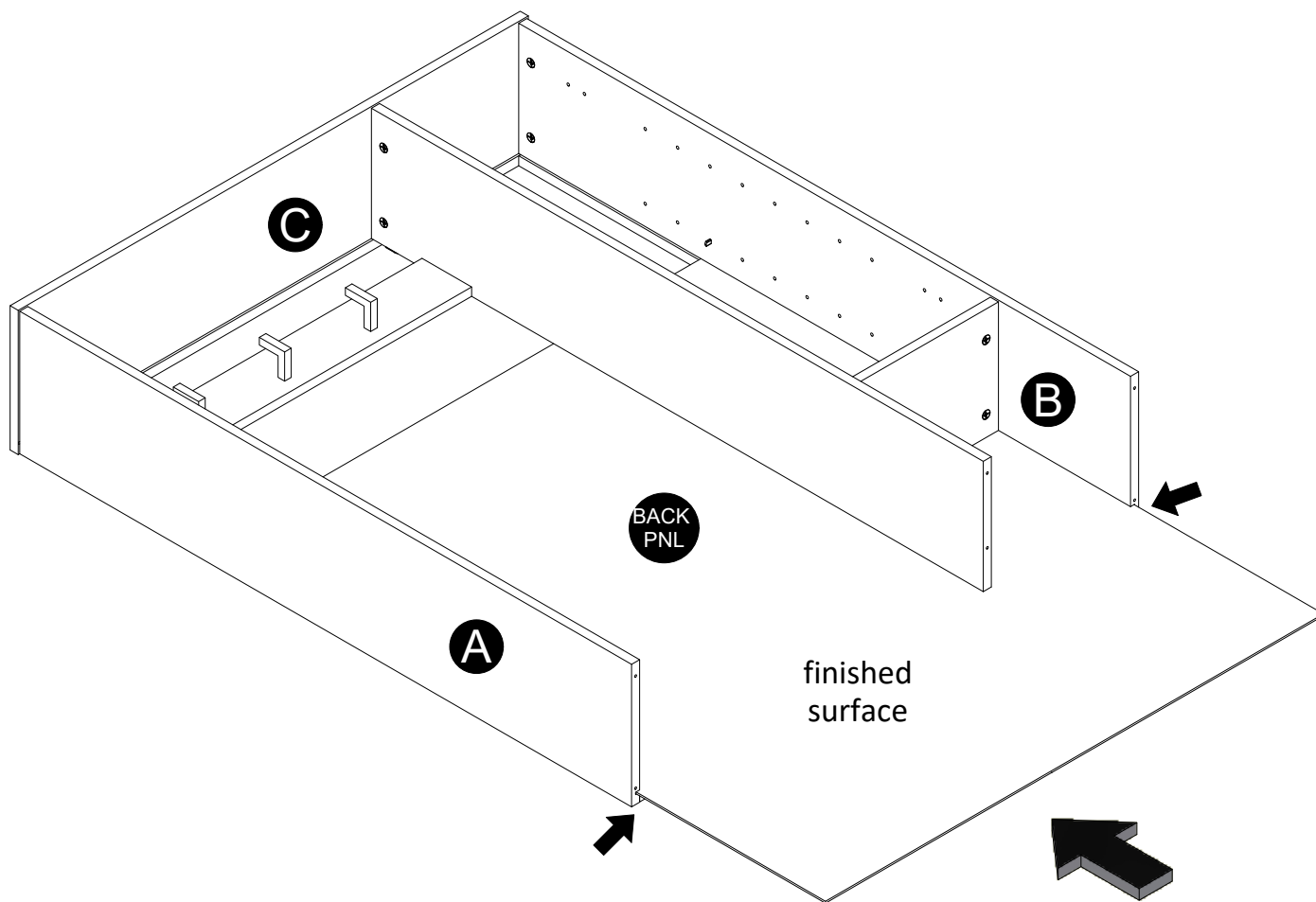

STEP 11

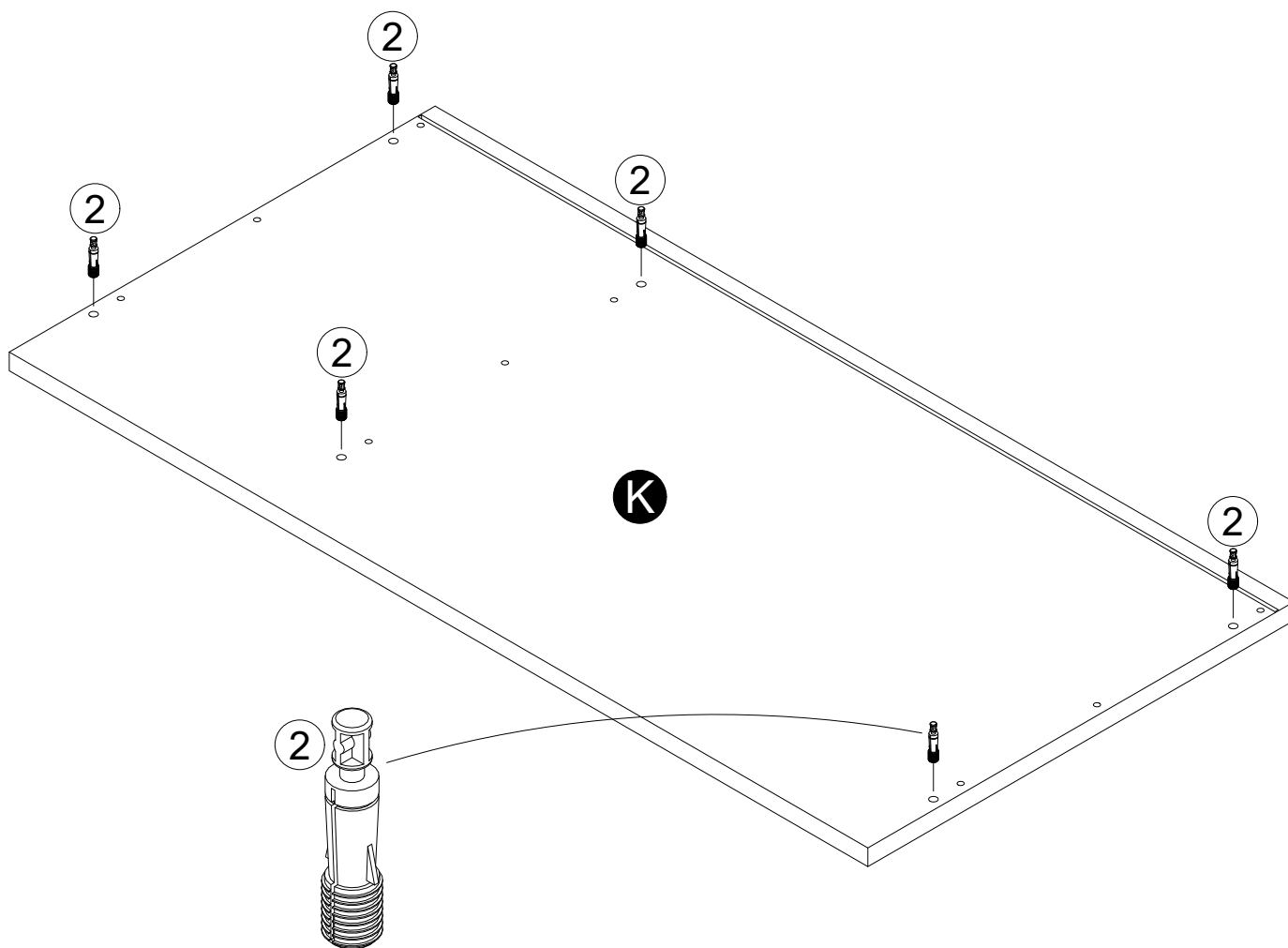
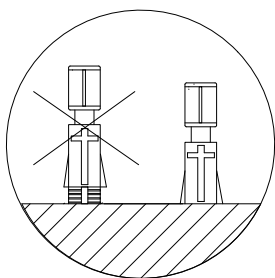
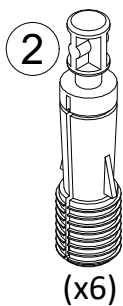

STEP 12

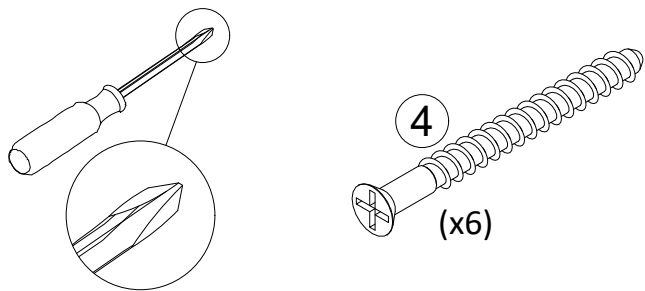

Finished Edges Up

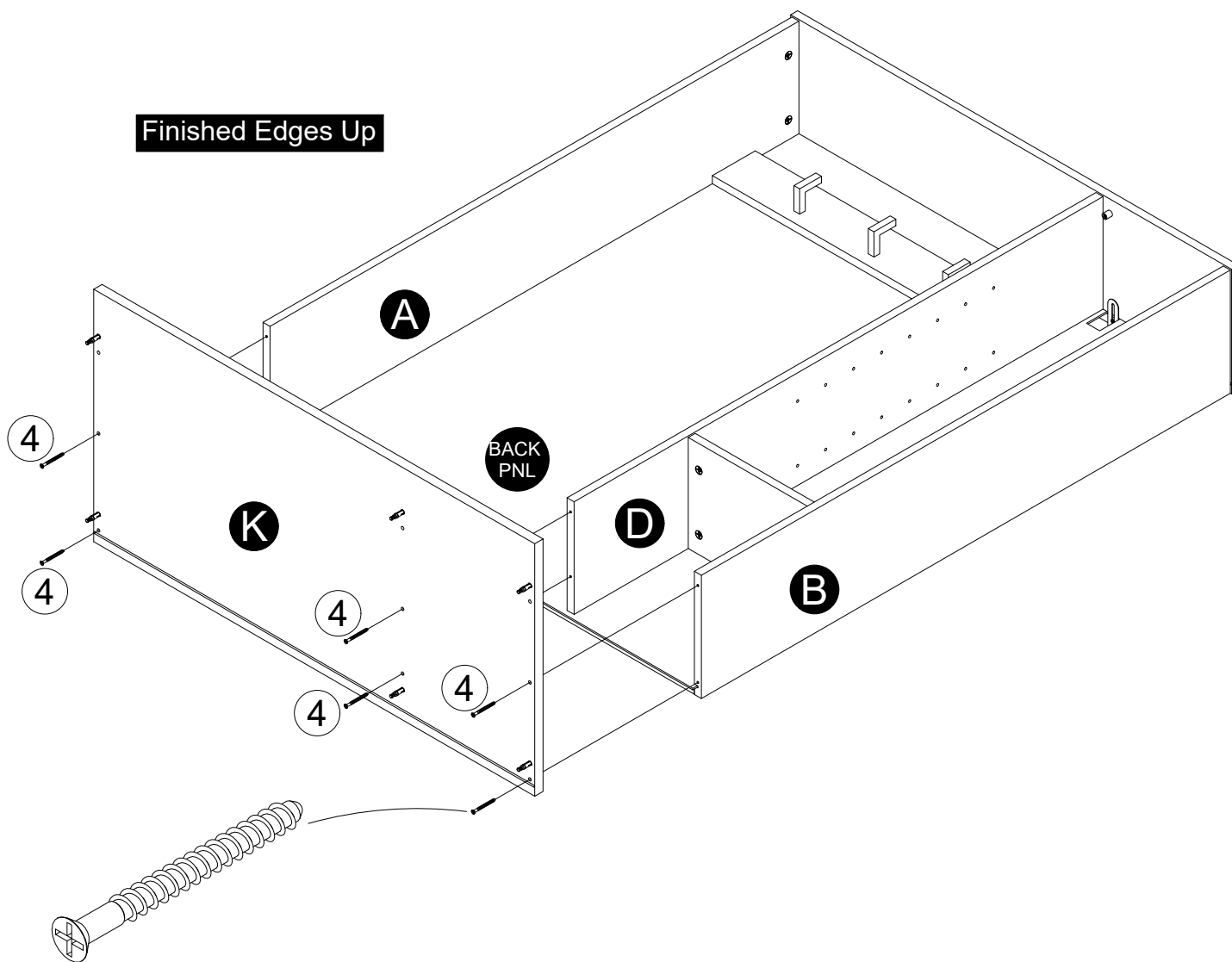

STEP 13

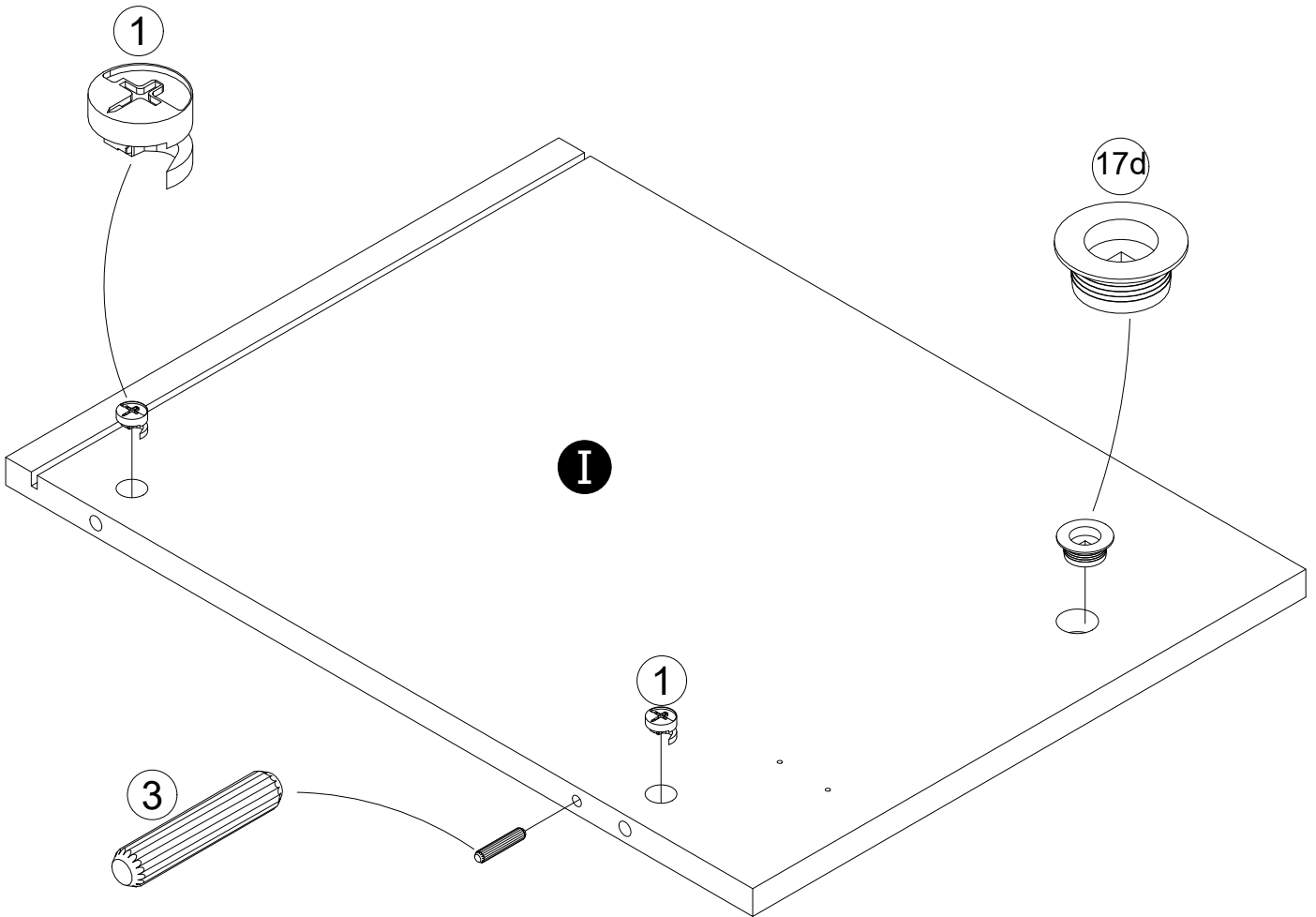
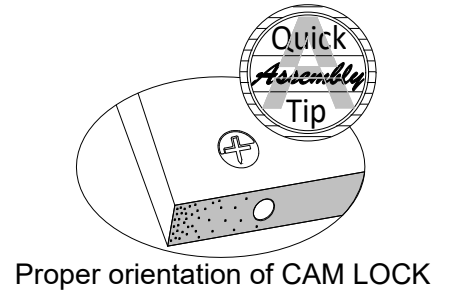
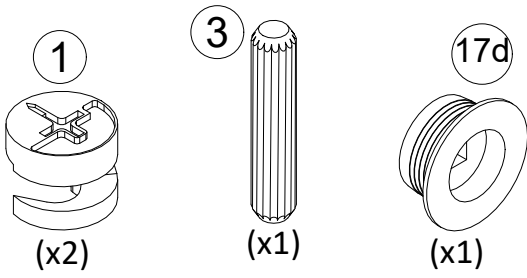

STEP 14

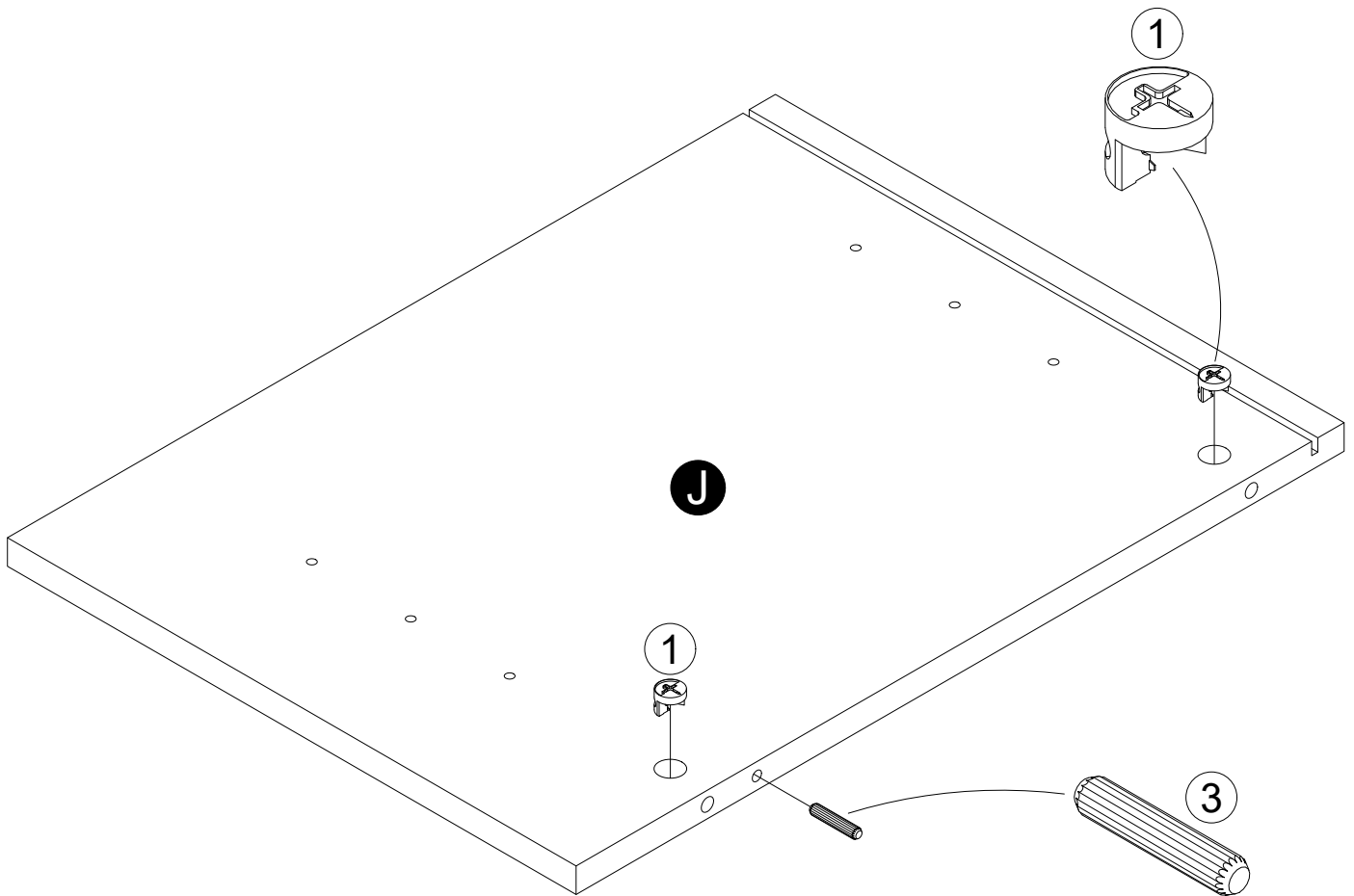
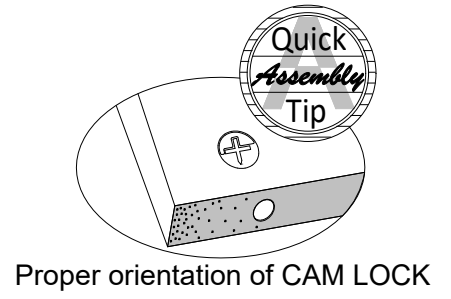
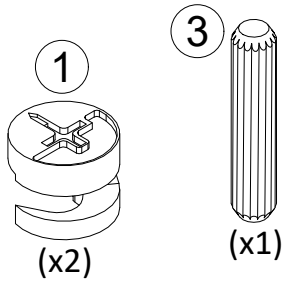

STEP 15

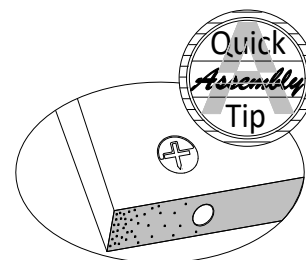
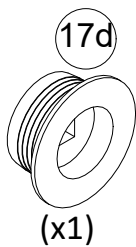
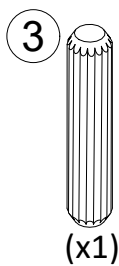
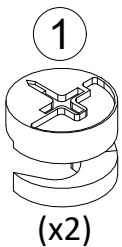

Proper orientation of CAM LOCK

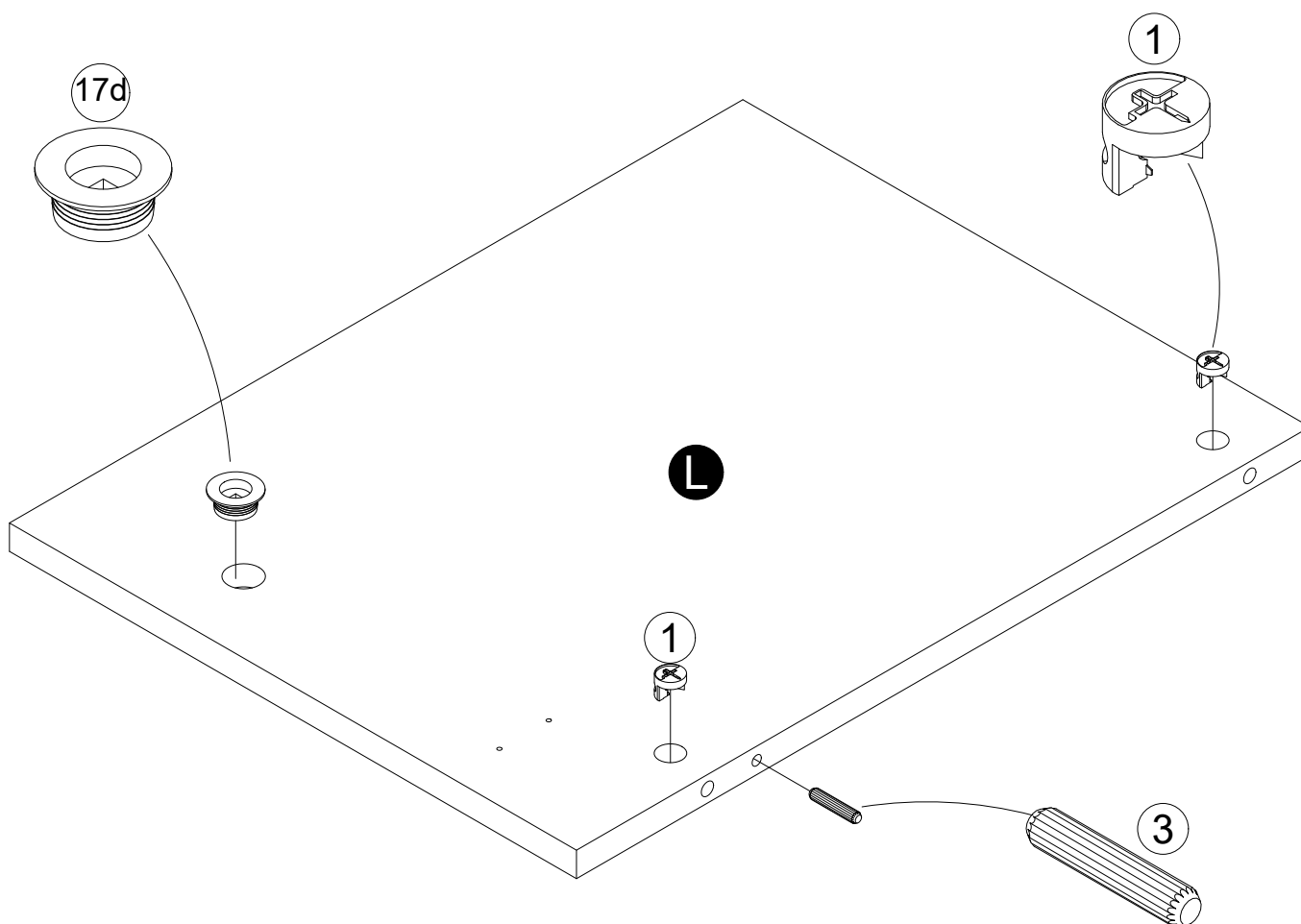

STEP 16

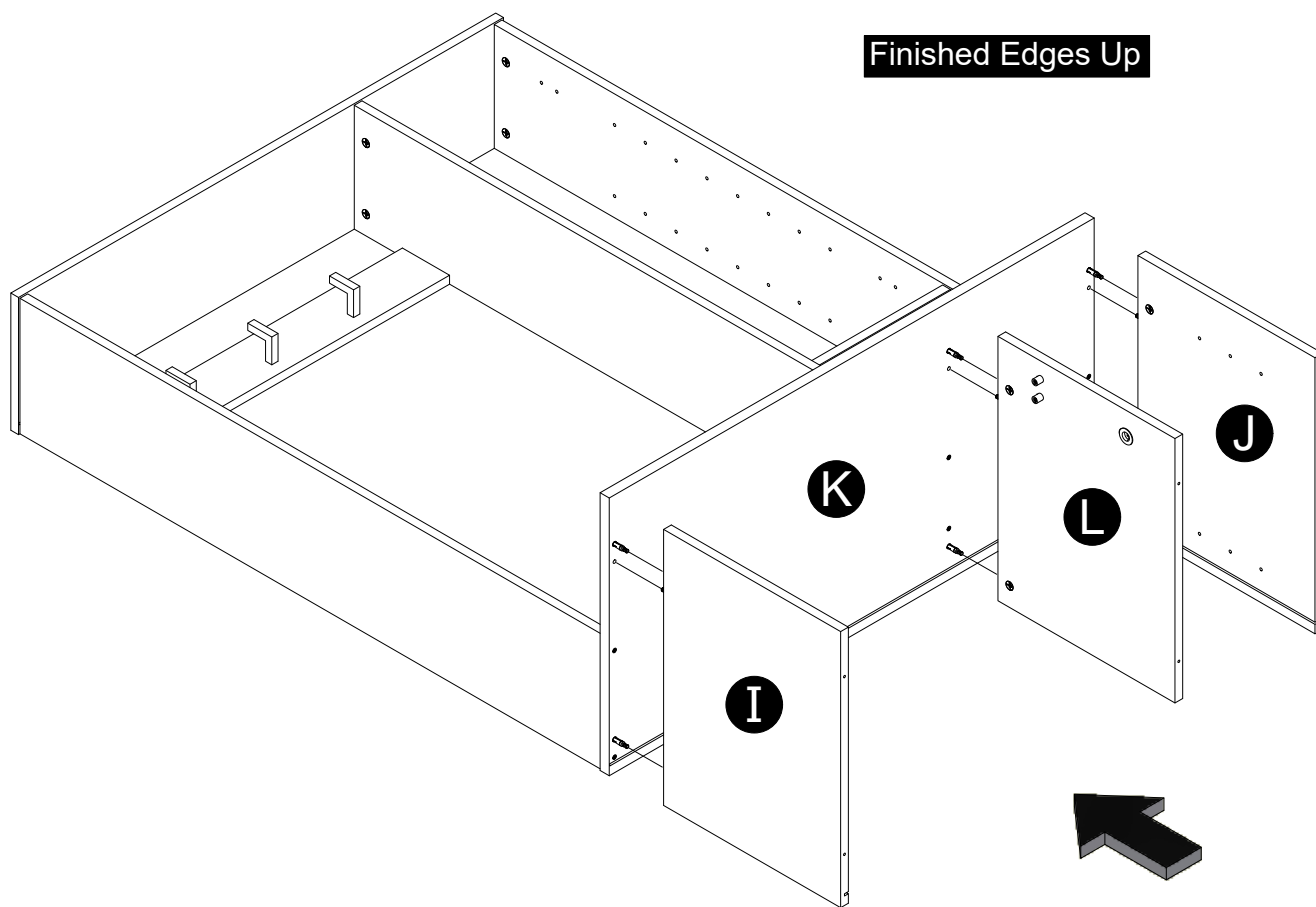
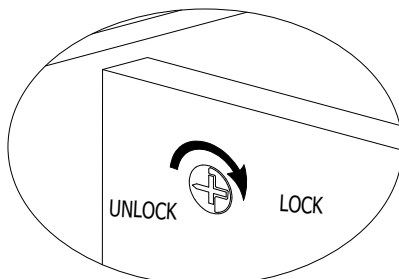
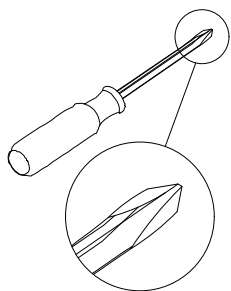

STEP 17

IMPORTANT! THE BACK PANEL IS A STRUCTURAL PART OF THIS UNIT AND MUST BE INSTALLED PROPERLY.

Unfold the back panel. With the finished surface facing up, slide the back panel into the groove in the lower left and lower right panels (I&J) seating into the groove in the center shelf (K).

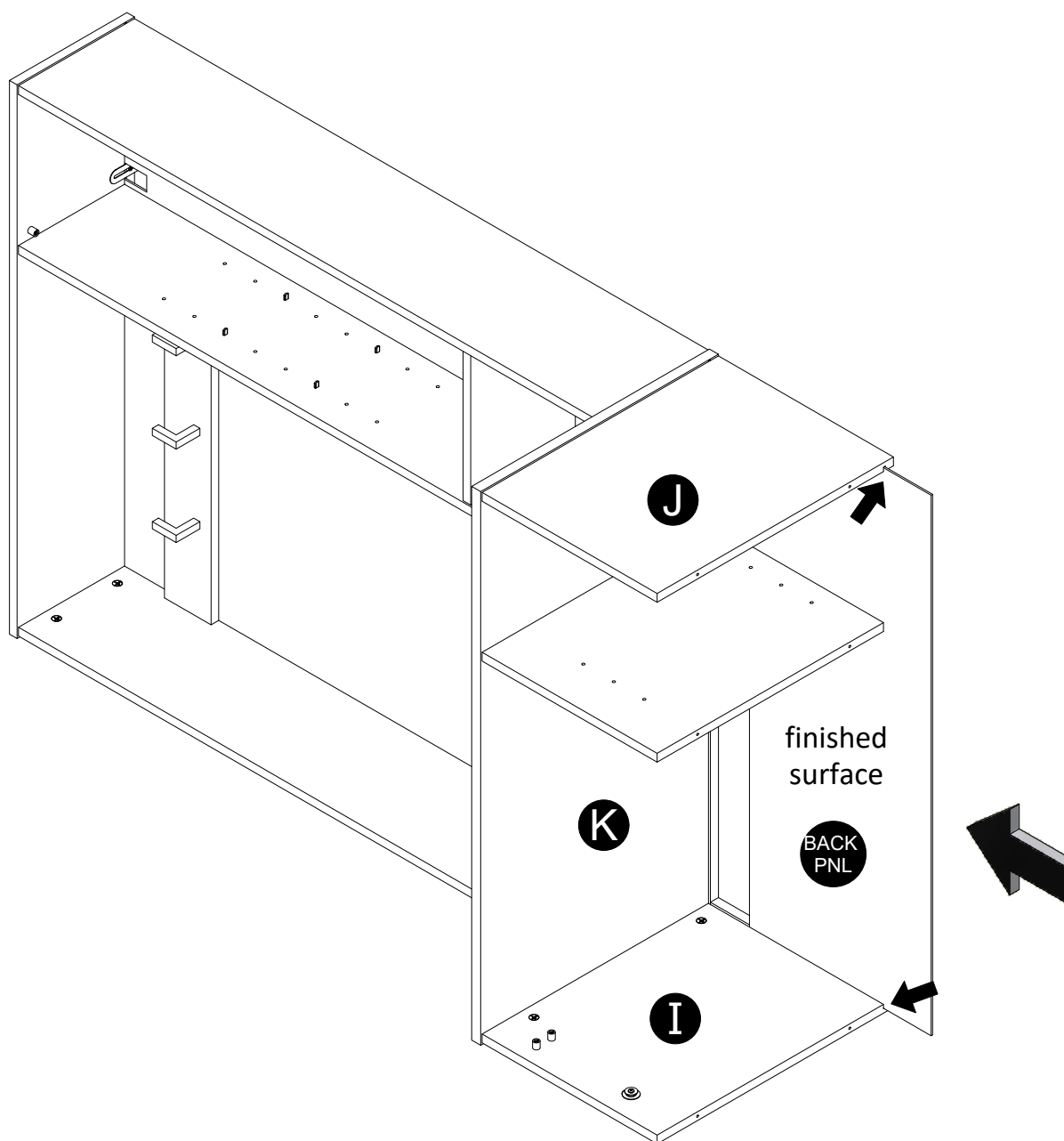

STEP 18

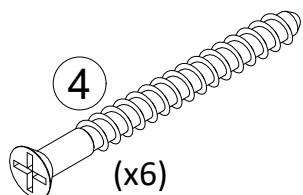
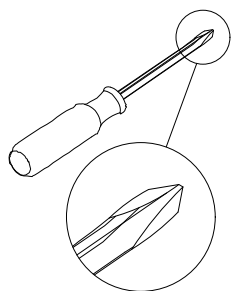

Finished Edges Up

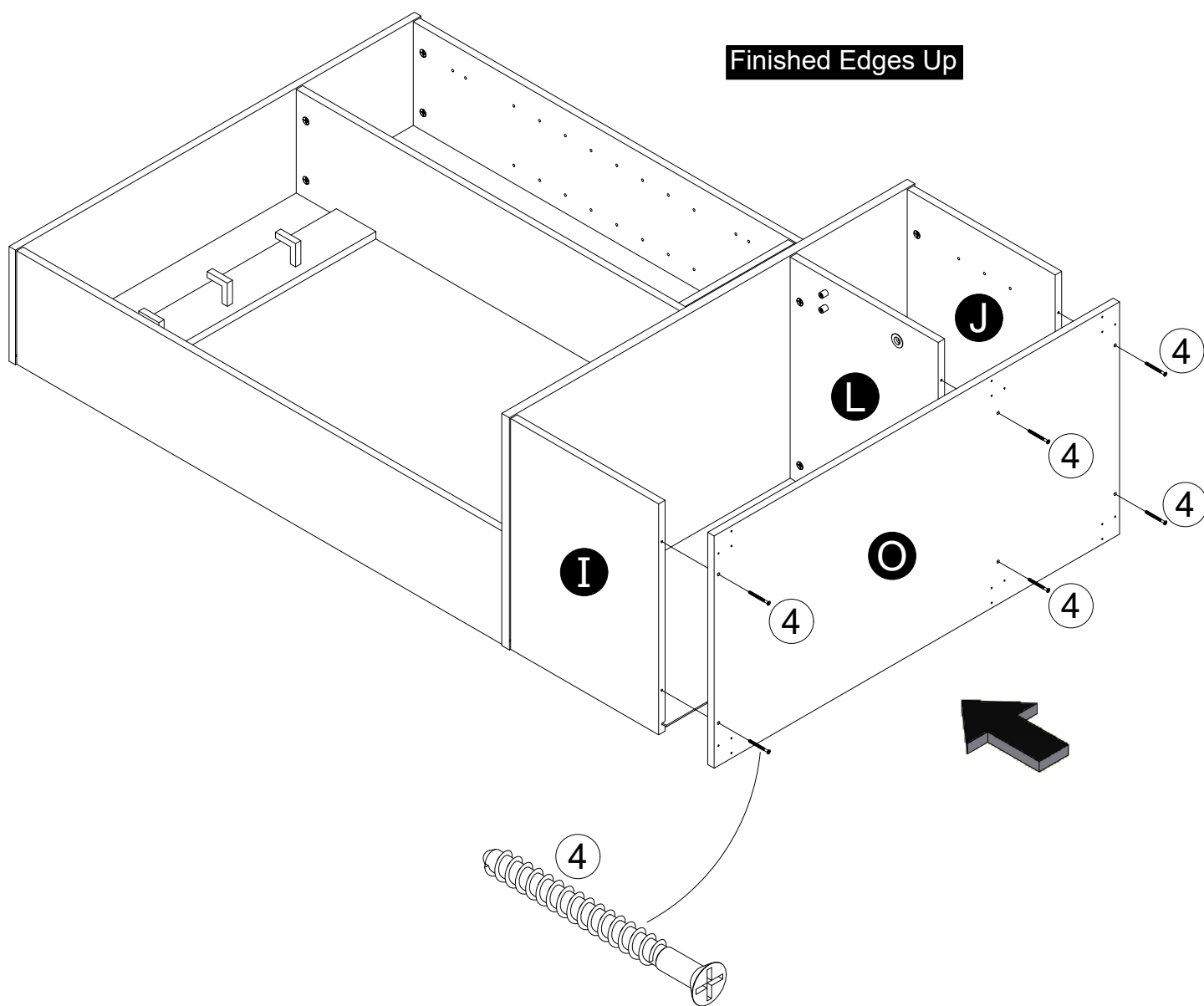

STEP 19

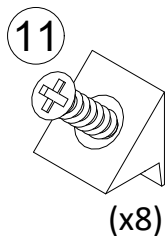
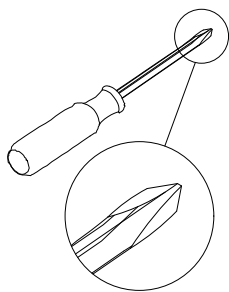

Position the wedge on the Back Panels and slide the lip into the groove. Tighten screw to lock in place.

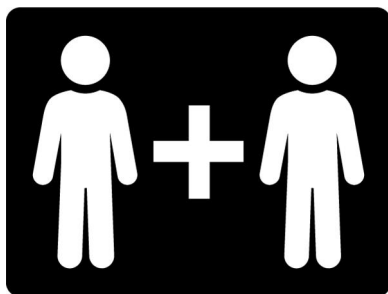
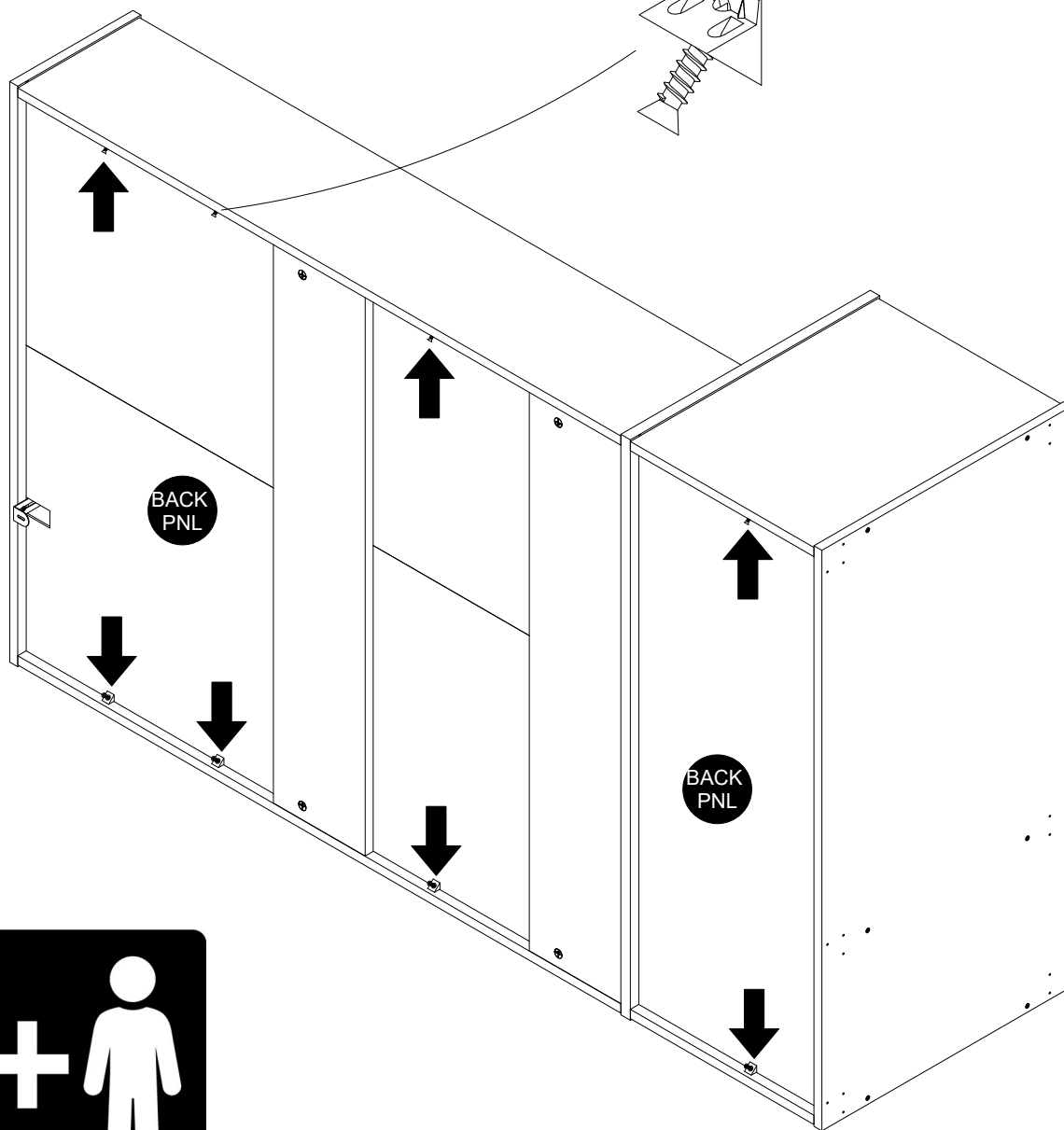
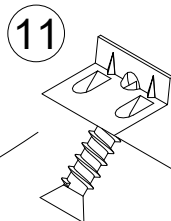

STEP 20

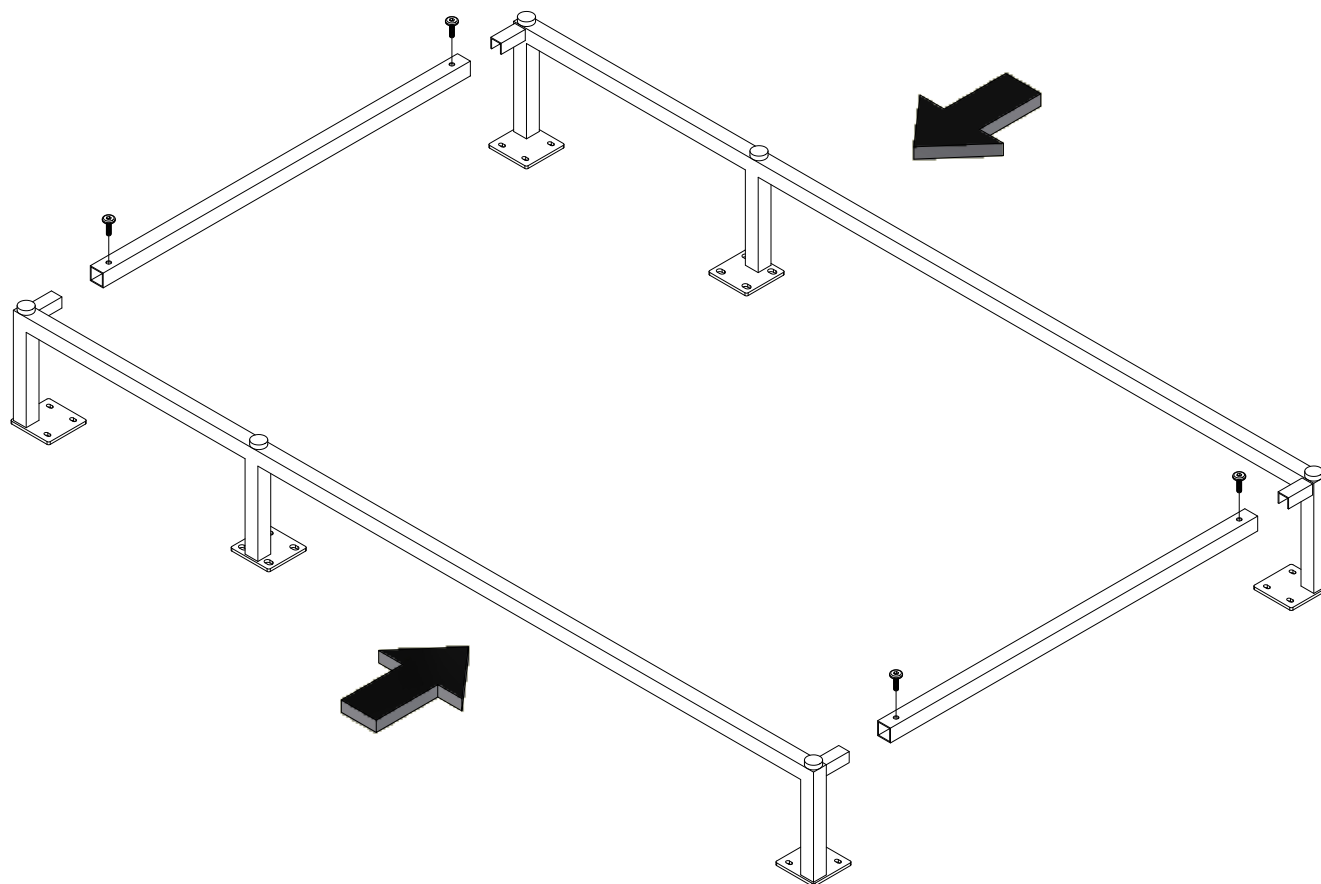
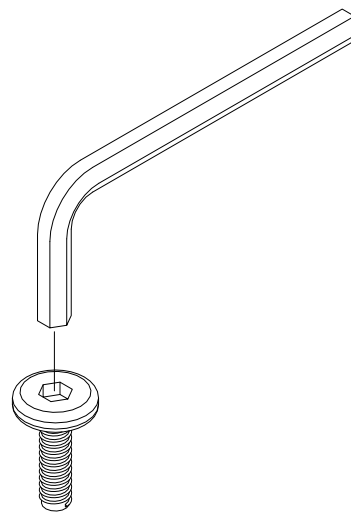
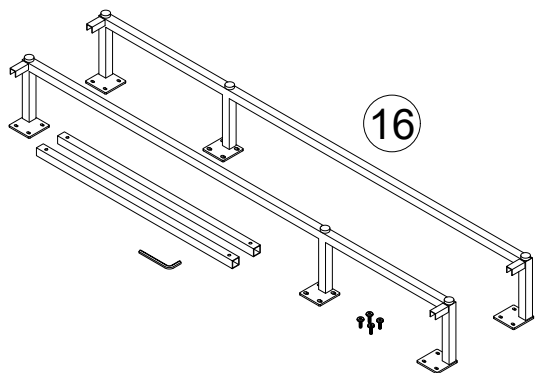

STEP 21

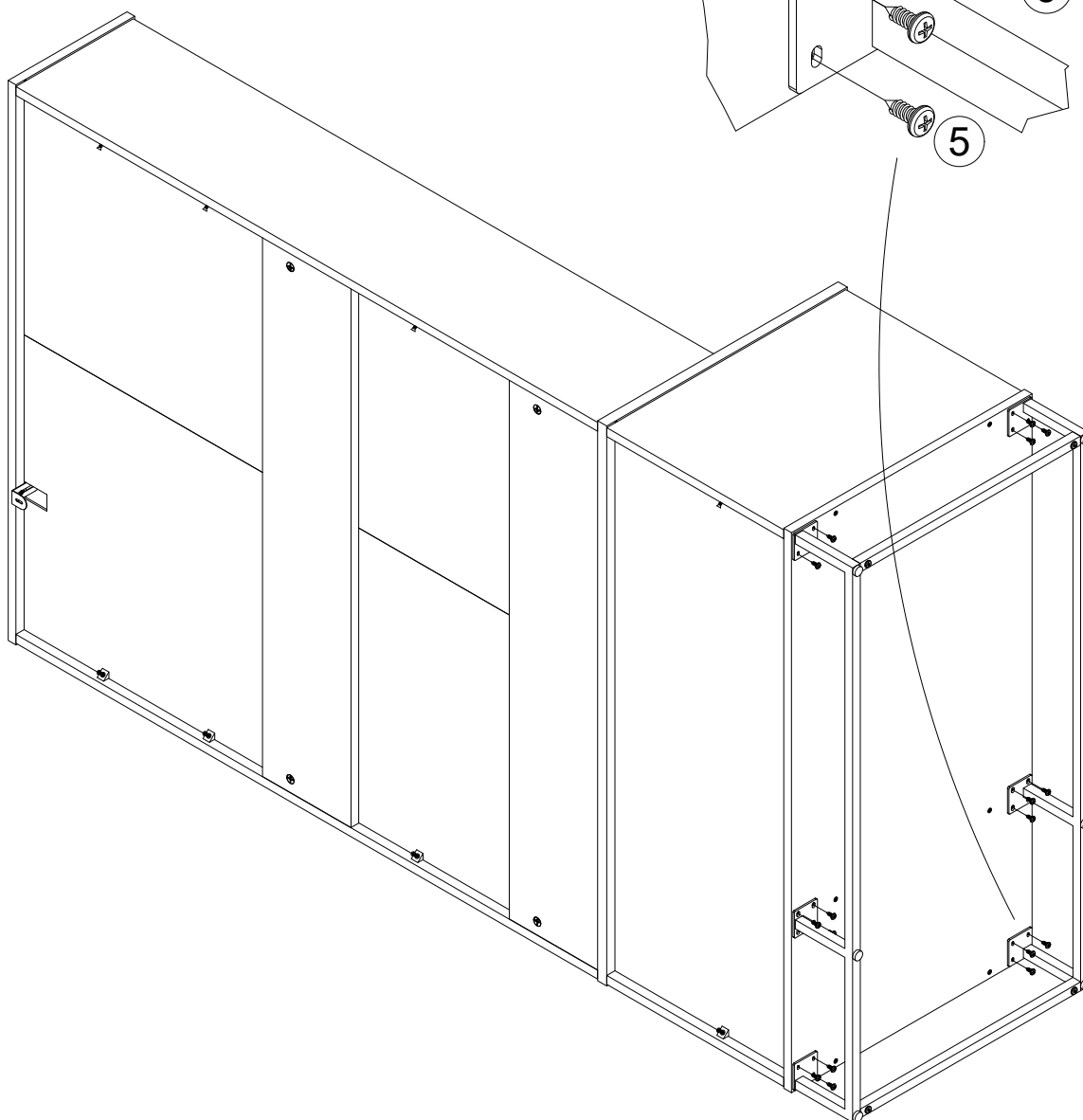
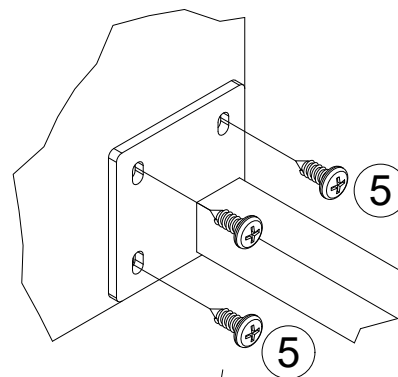
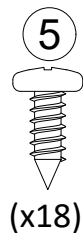
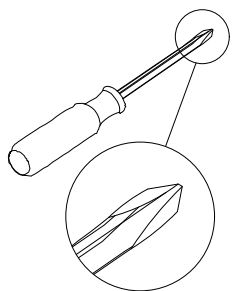

STEP 22

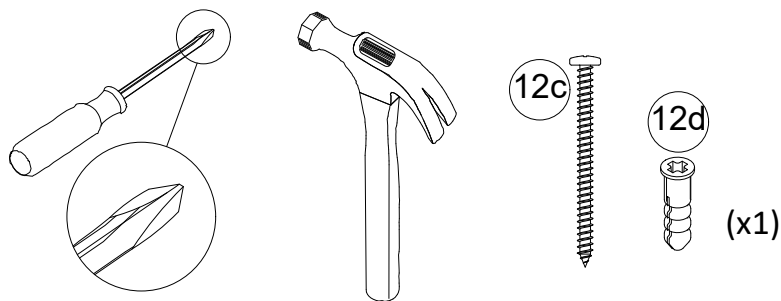

For Masonry, Concrete, or other wall materials:

Consult your local hardware store for appropriate anchors to securely attach the safety bracket.

IMPORTANT: THIS UNIT MUST BE SECURE TO THE WALL TO HELP PREVENT TIPOVER. FOLLOW THESE INSTRUCTIONS TO INSTALL THE ANTI-TIPPING SAFETY BRACKET PROVIDED WITH THIS PRODUCT.

WARNING

Serious or fatal crushing injuries can occur from furniture tipover.

To prevent tipover:

- * Install tipover restraint provided
- * Place heaviest items in the lowest drawers
- * Unless specifically designed to accommodate, do not set TVs or other heavy objects on the top of this product
- * Never allow children to climb or hang on drawers, door, or shelves
- * Never open more than one drawer at a time

Use of tipover restraints may only reduce, but not eliminate the risk of tipover

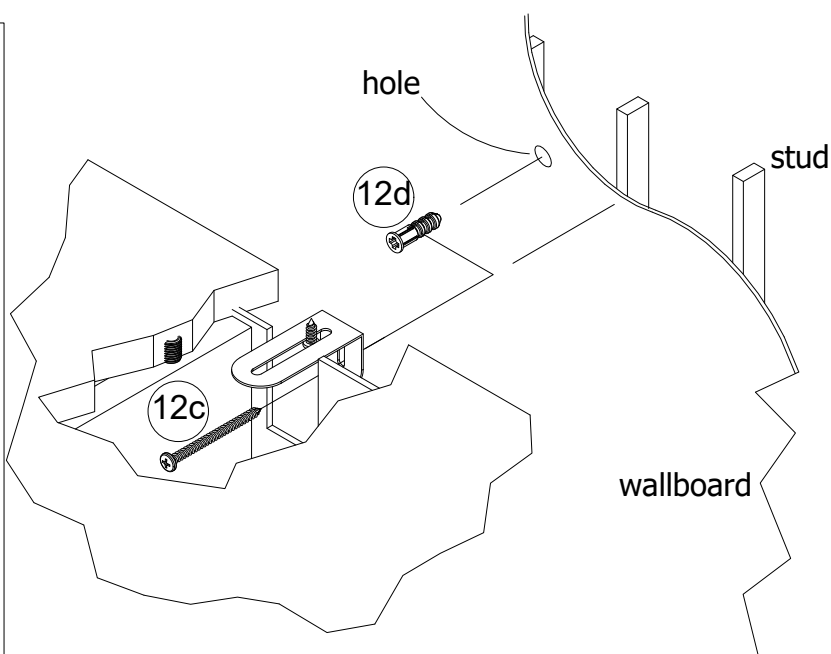

OPTION 1: Attachment into a wall stud (preferred method)

Using a stud finder, locate a stud in the wall. Place your unit against the wall, with the safety bracket aligned in this location. To make driving the screw easier, you can drill a 1/8" diameter pilot hole (3mm) through the safety bracket into the stud. Drive the screw through the safety bracket into the wall stud. Tighten the screw that was not fully tightened in step 1.

OPTION 2: Attachment into drywall

Locate your unit where desired against a wall and mark the wall through the safety bracket, then move your unit aside. Drill a 3/16" diameter hole (5mm) into the wallboard. Tap the wall anchor into the hole until it is flush. Move your unit into location and fasten the wall bracket to the wall anchor with the screw. Tighten the screw that was not fully tightened in step 1.

STEP 23

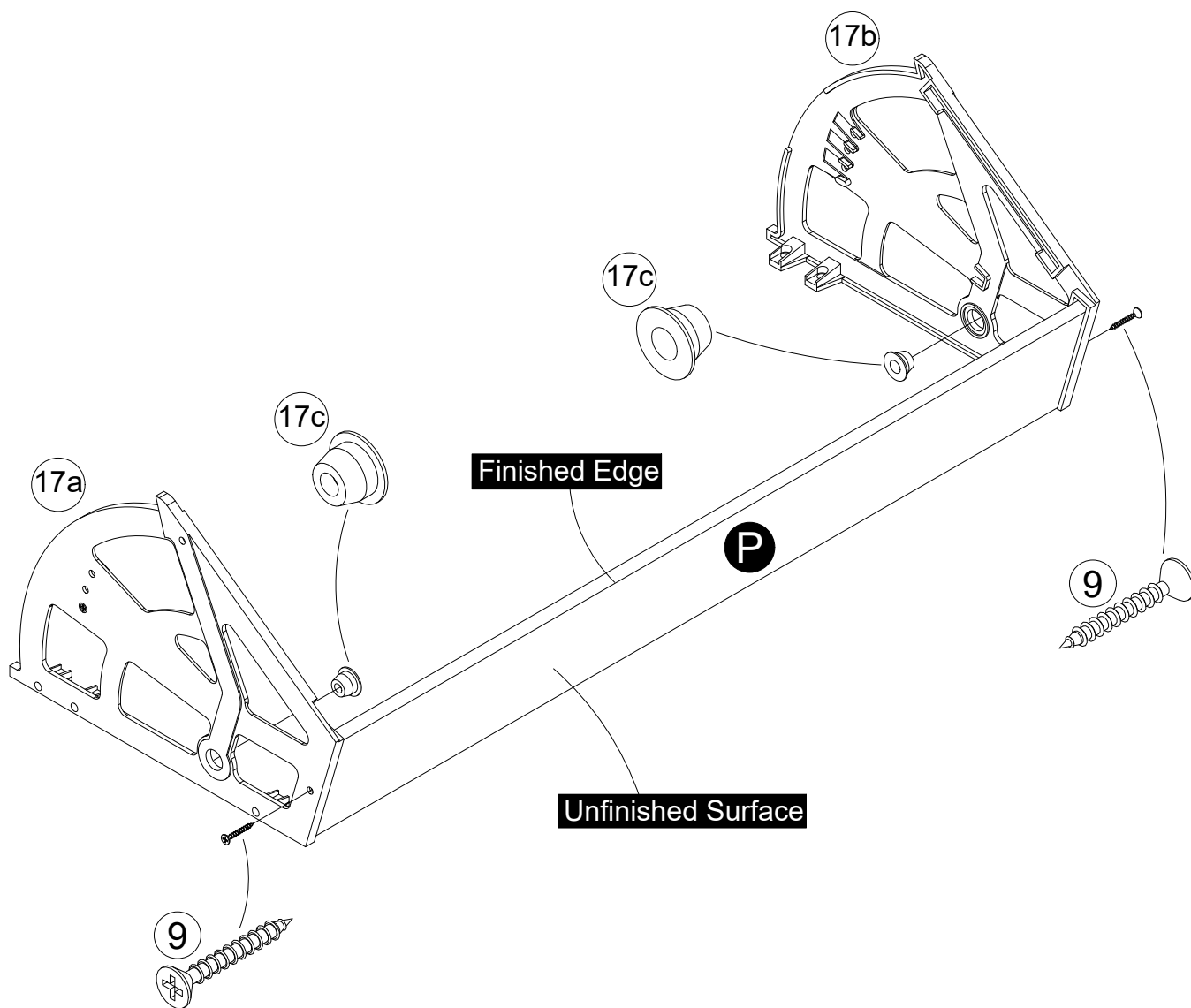
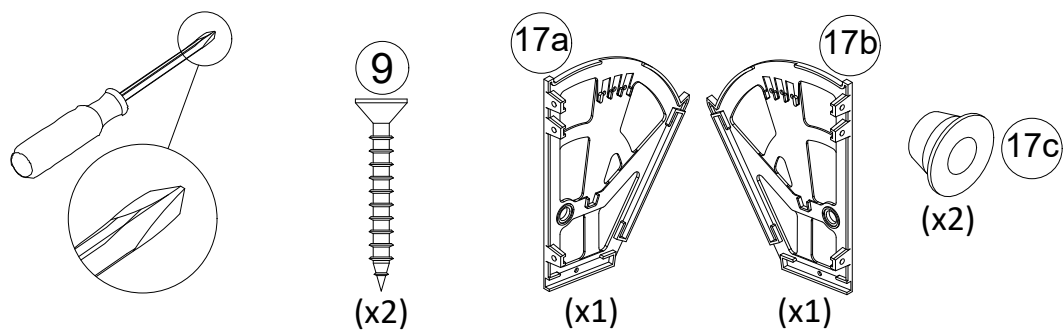

STEP 24

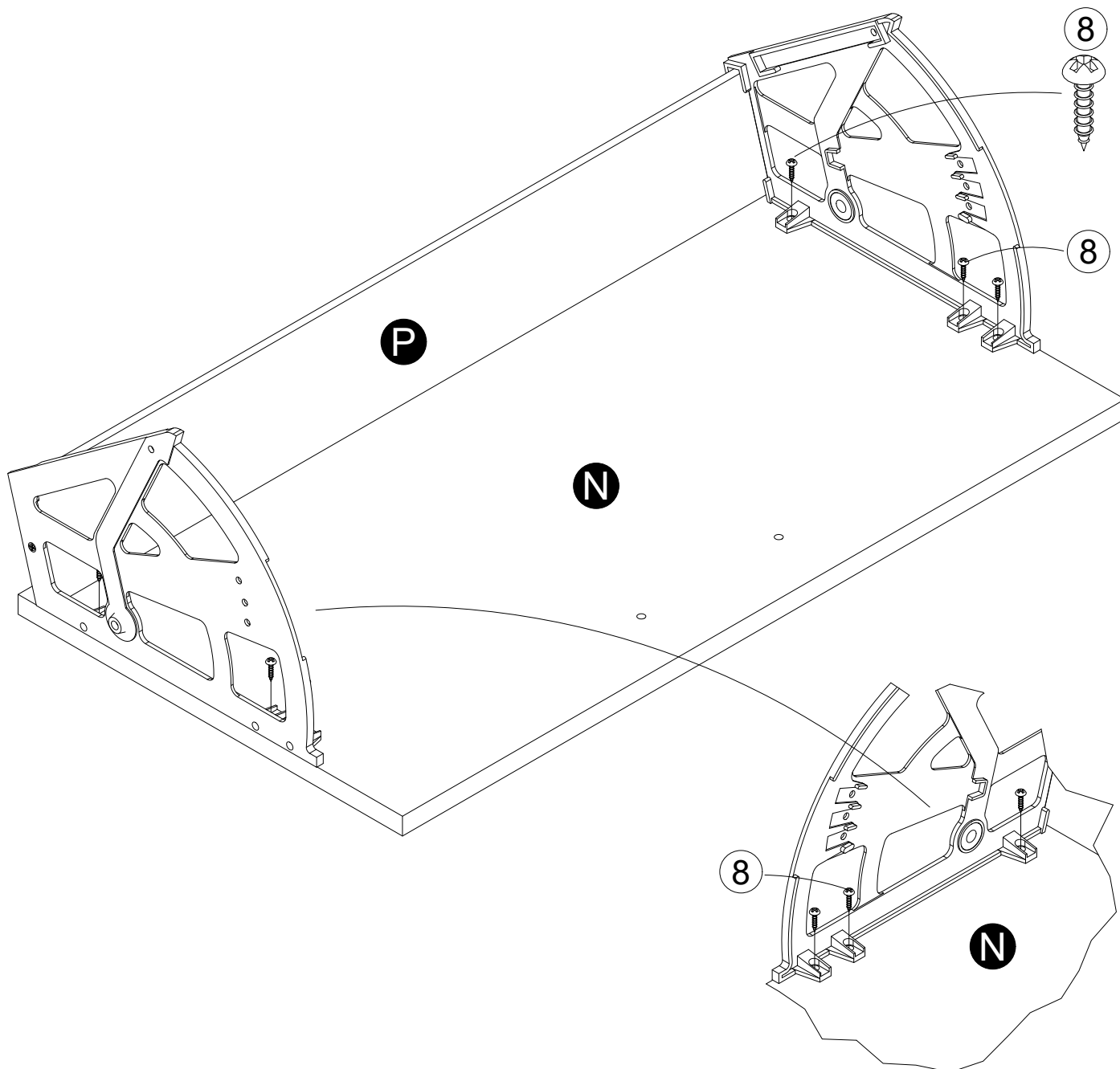
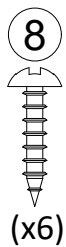
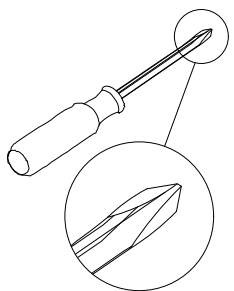

STEP 26

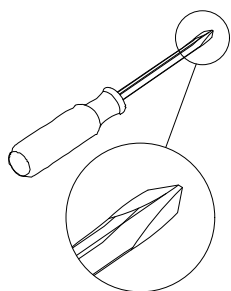

Position the shoe cubby assembly as shown. Position the inner bushings into the outer bushings that were inserted on the Lower Left Panel (I) and the Lower Partition (L).

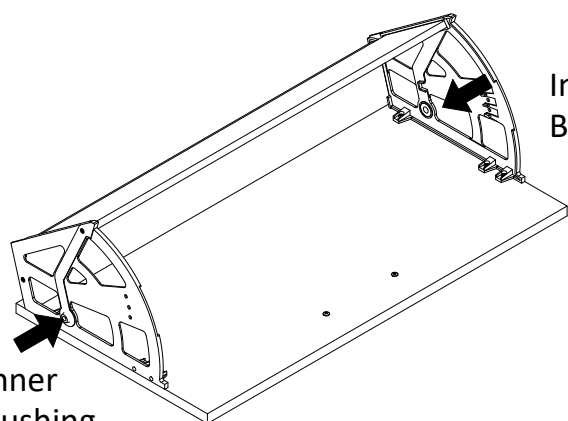
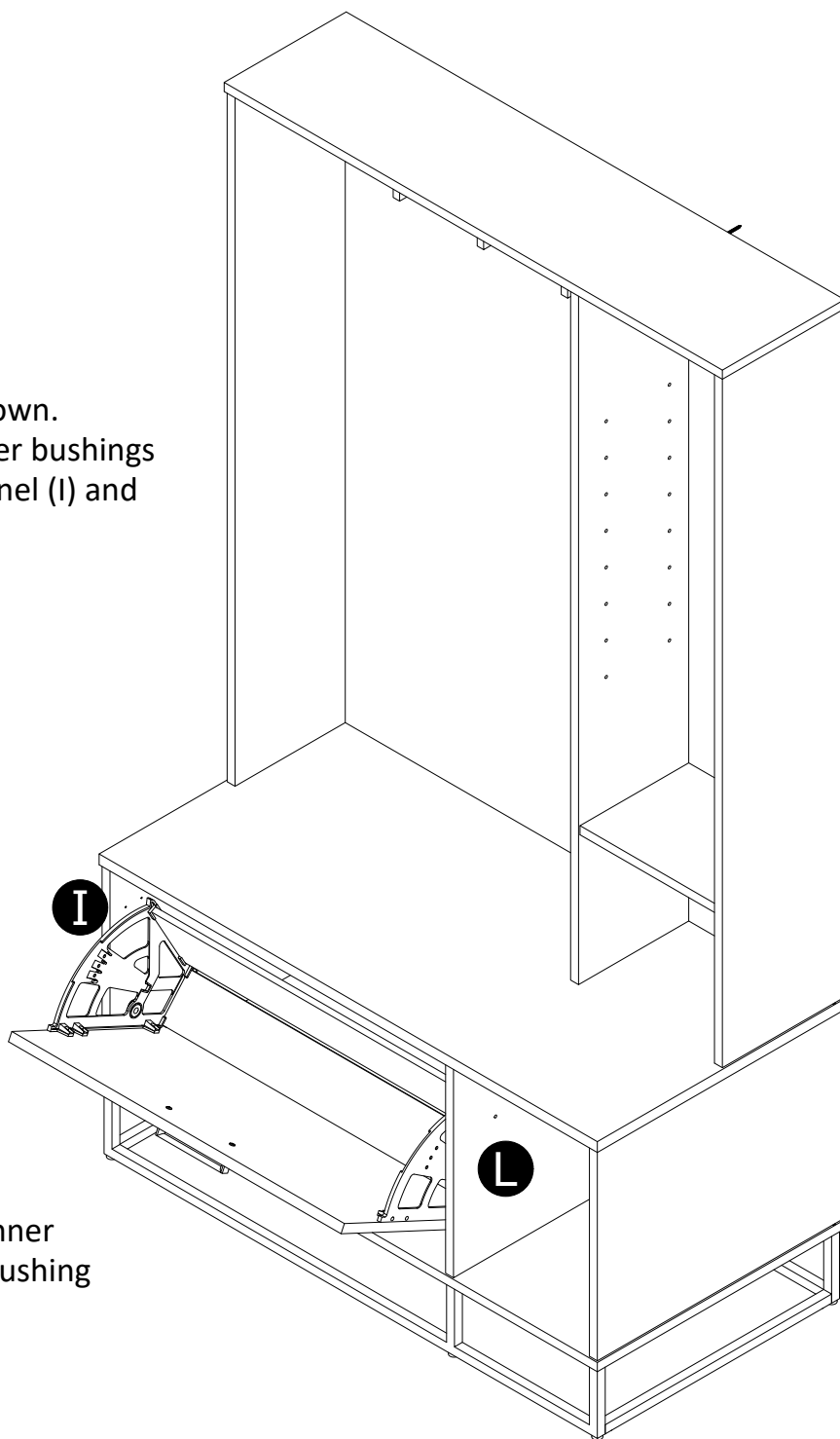

Inner Bushing

Inner Bushing

STEP 27

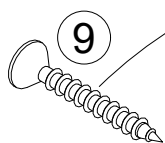
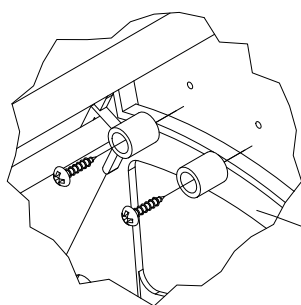
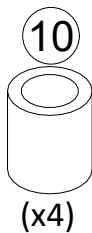
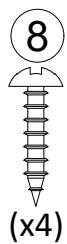
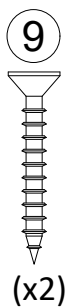
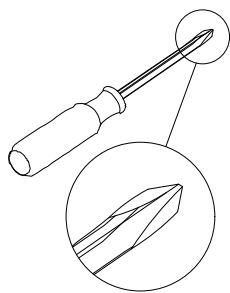

Finished Edge

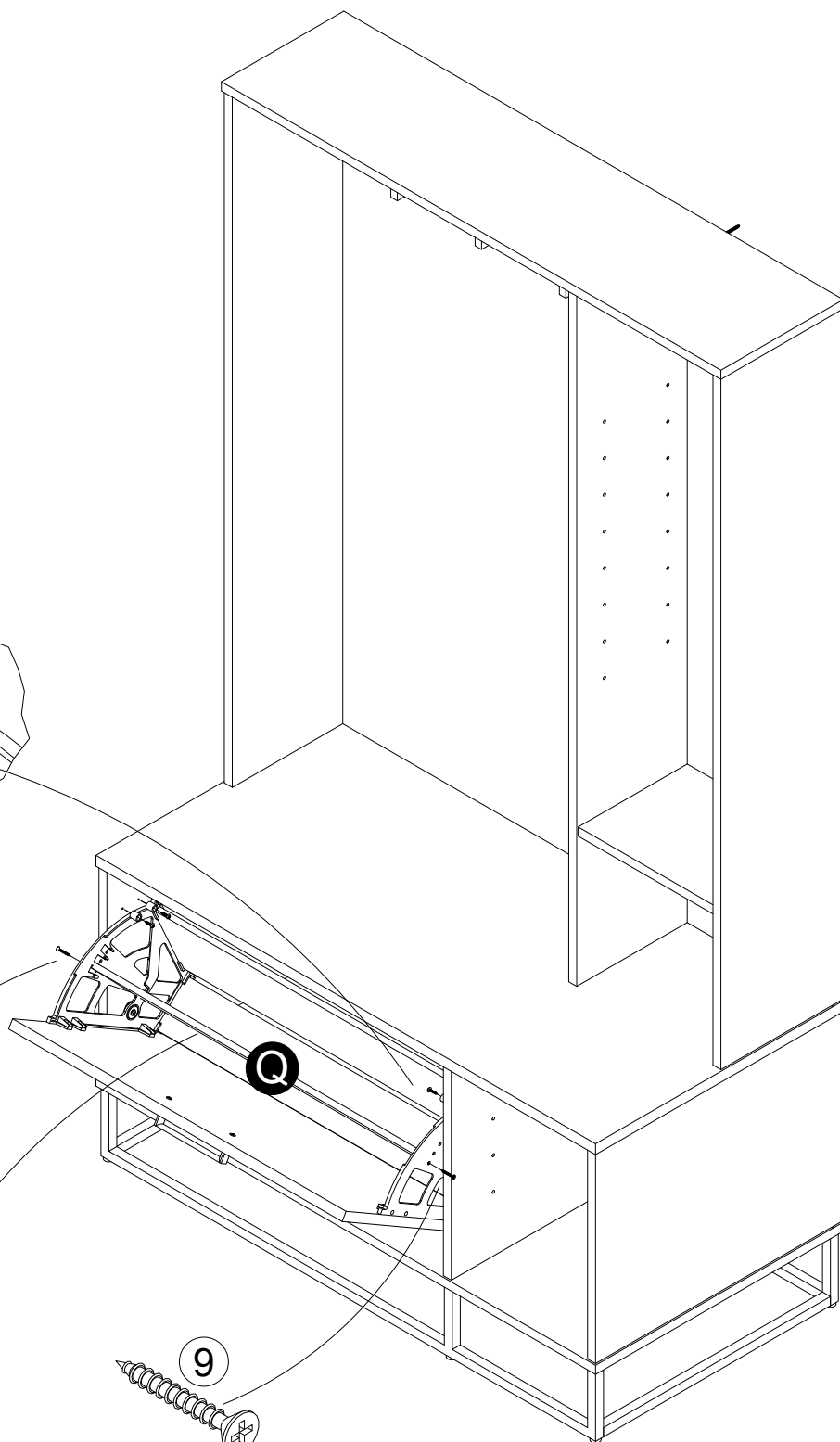
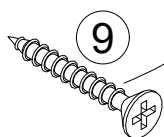

STEP 28

You can make one half of the shoe opening larger by removing the two screws attaching the center shoe panel (Q) and re-positioning it in the forward or rear space and re-attaching the two screws.

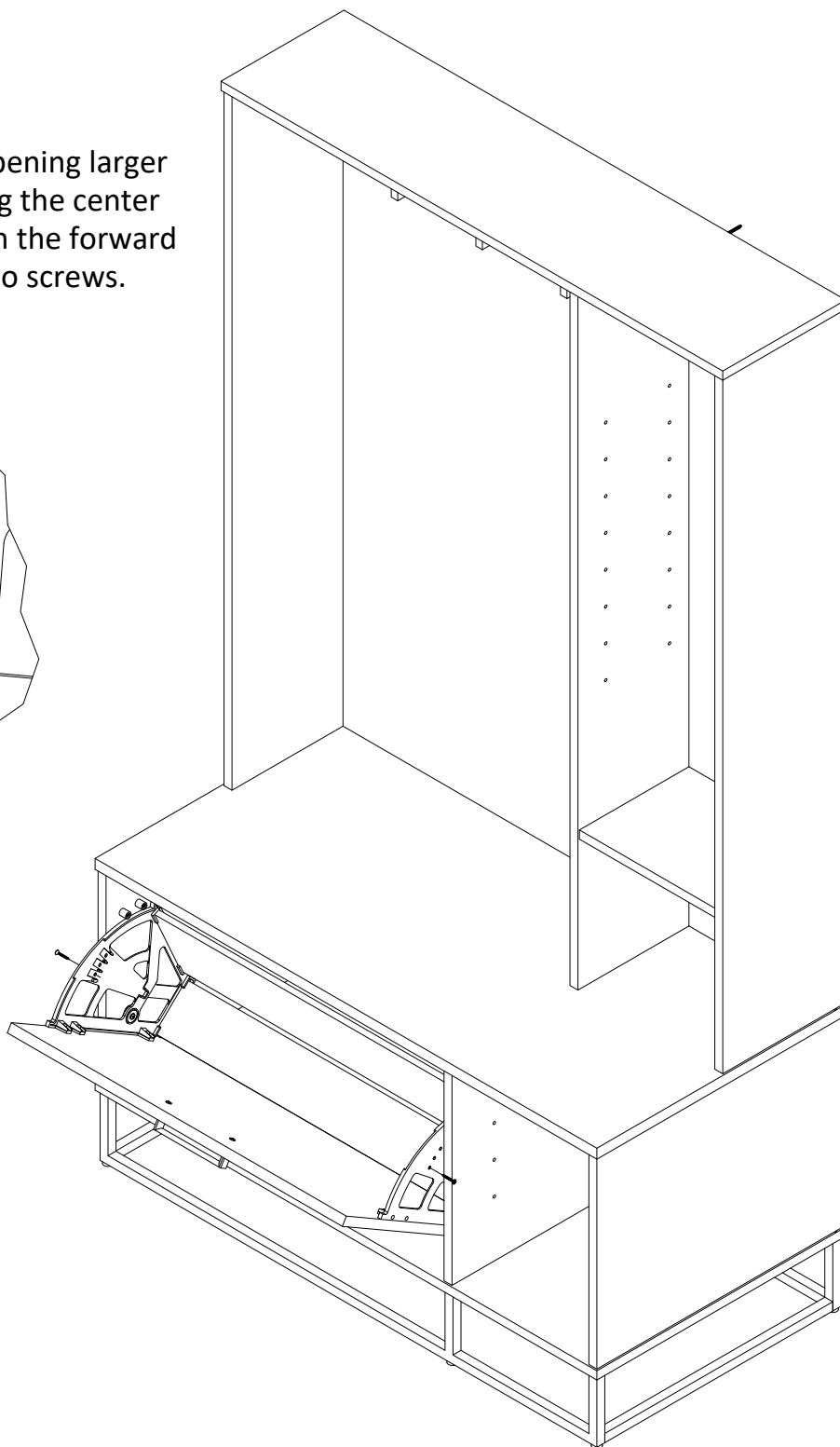
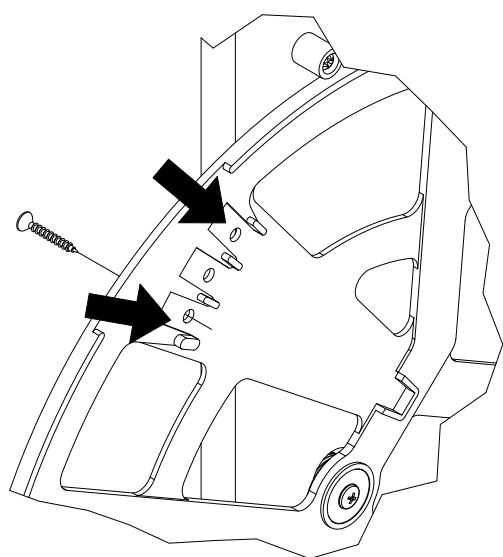

STEP 29

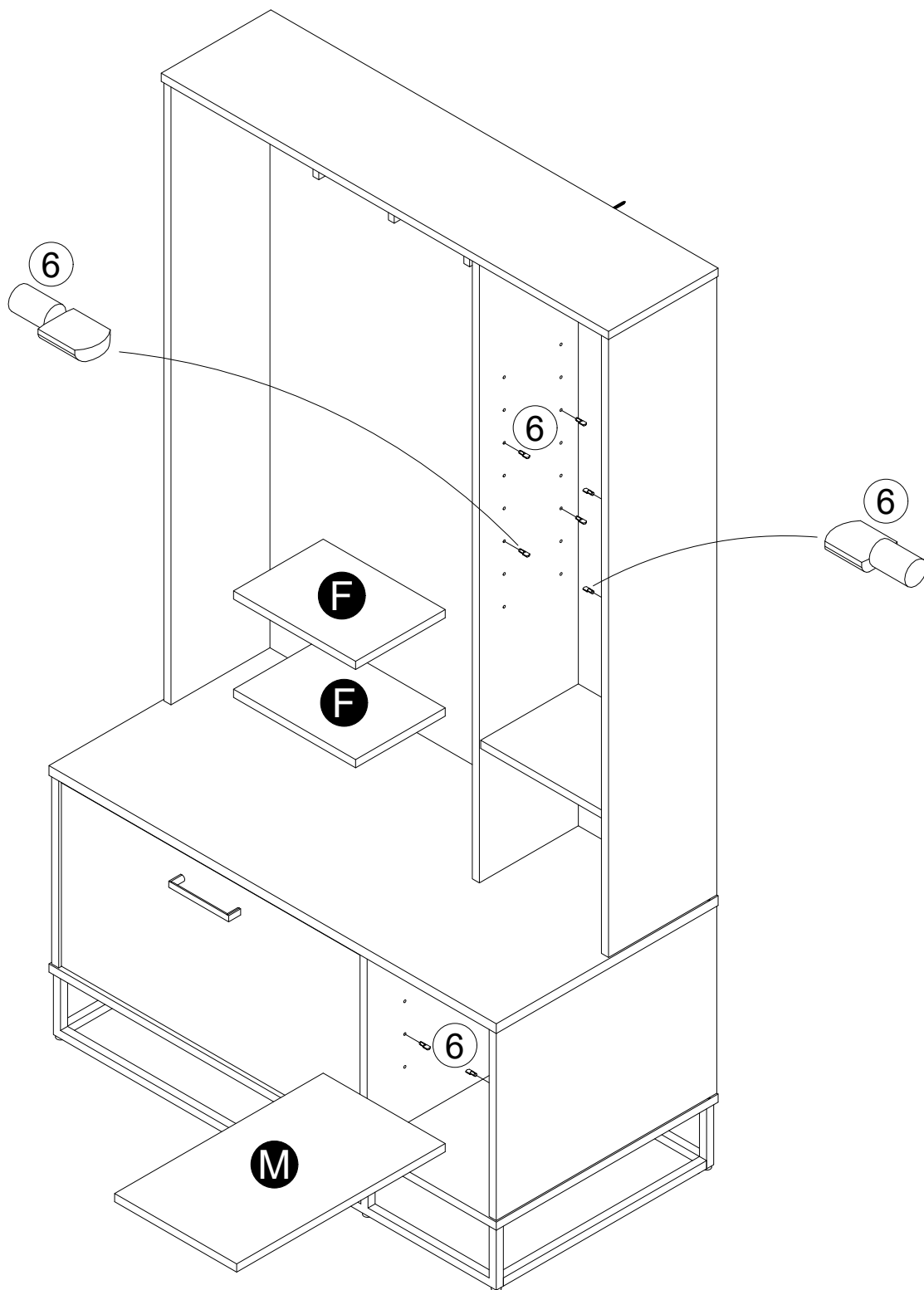
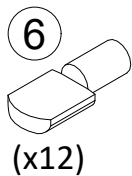

STEP 30

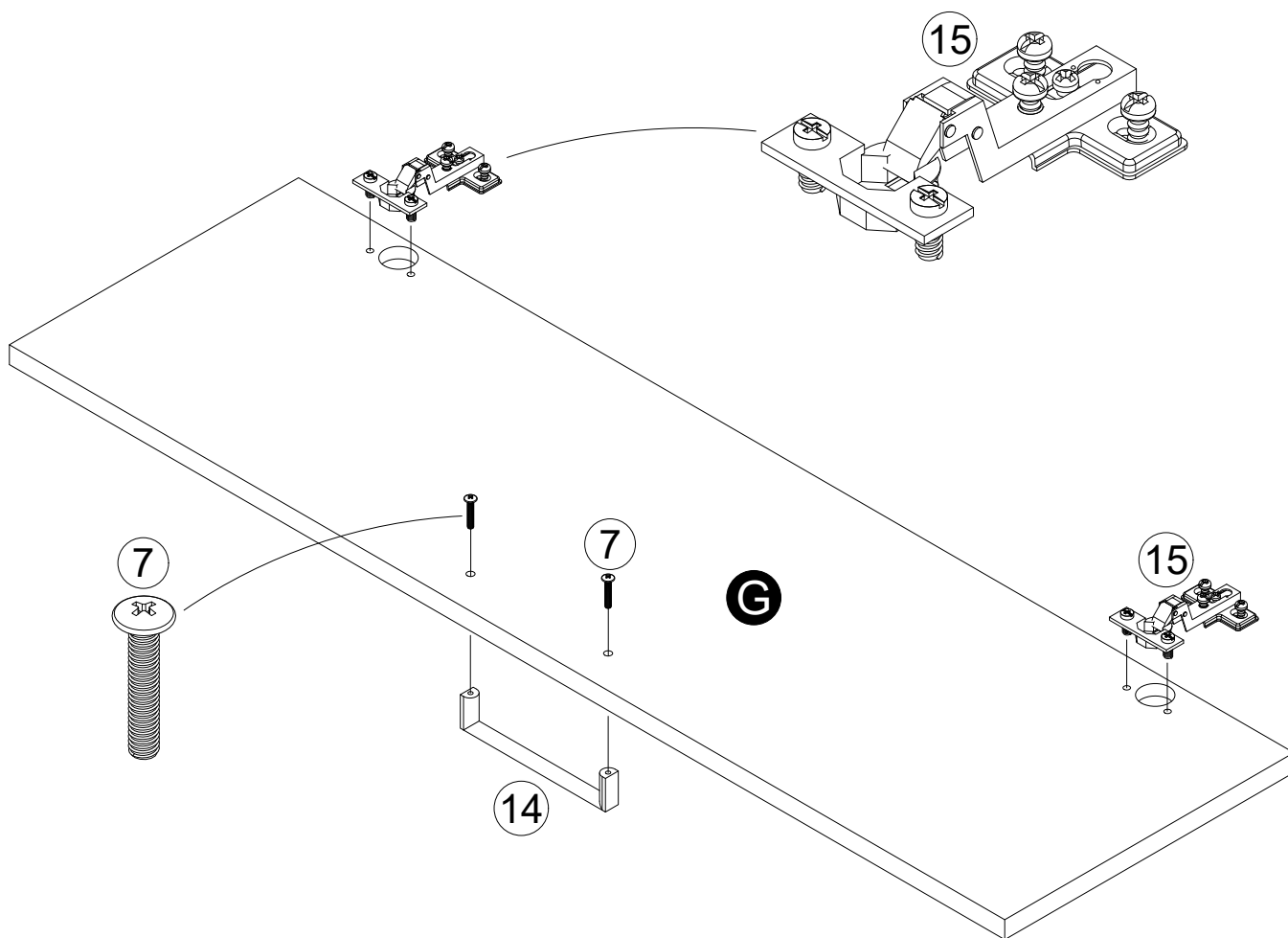
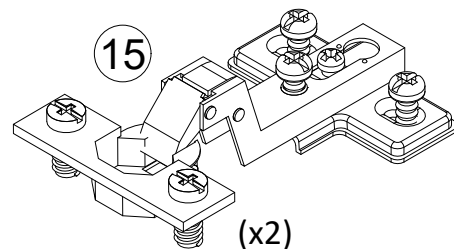
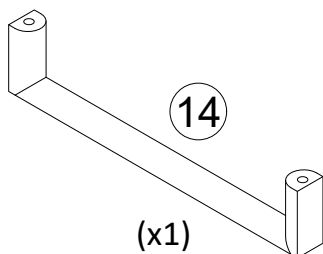
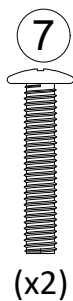
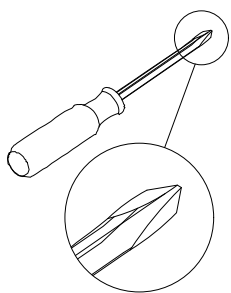

STEP 31

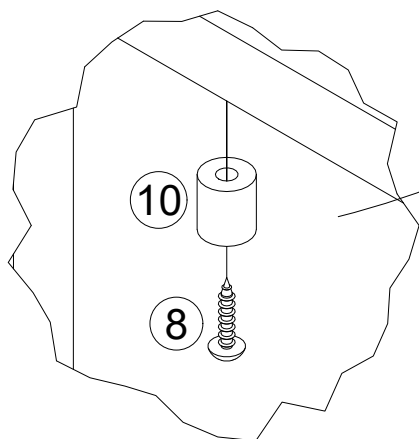
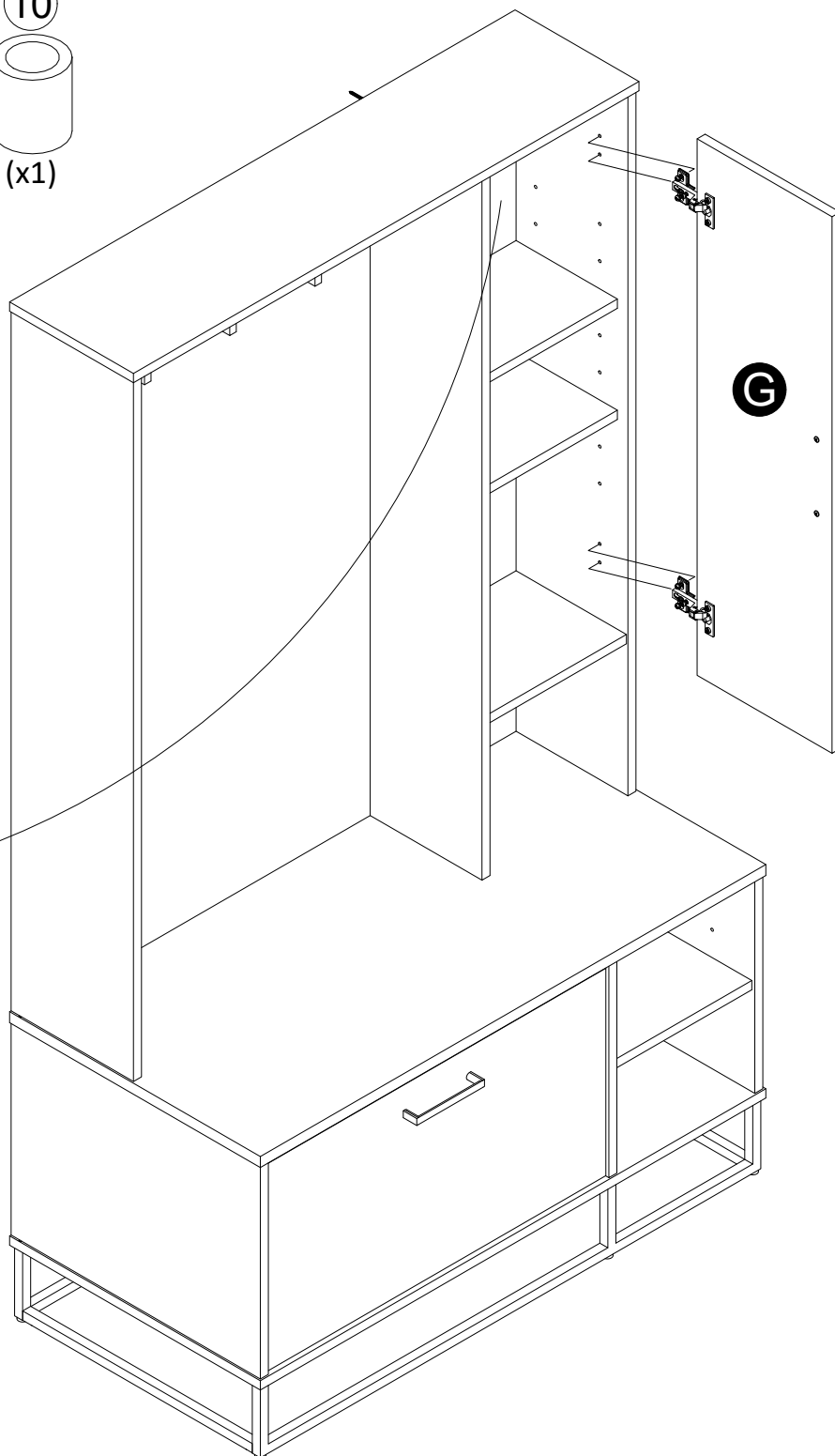
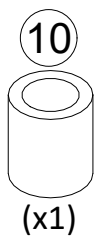
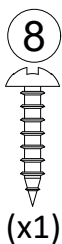
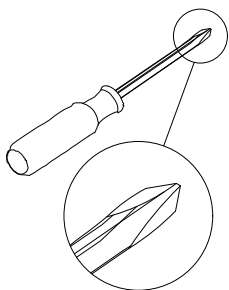

STEP 32

Door Adjustment

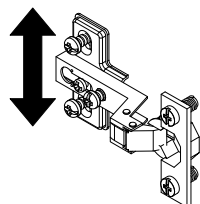
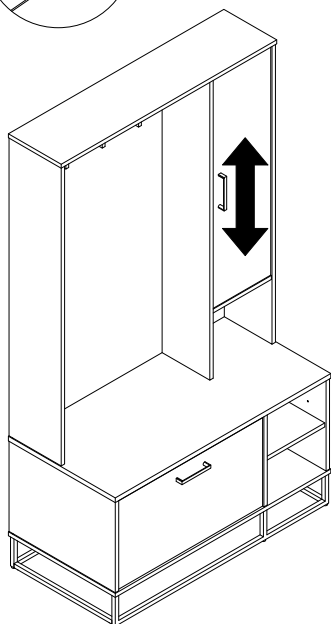
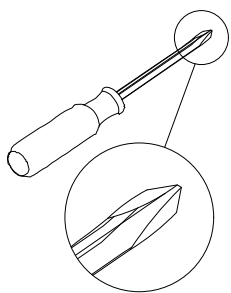

To adjust the vertical height:

Loosen the screws "A" on both hinges. They are usually in slotted holes which allows you to adjust up or down by a few mm. Then tighten back up.

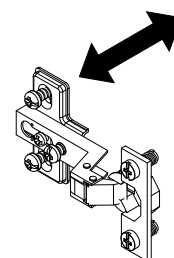
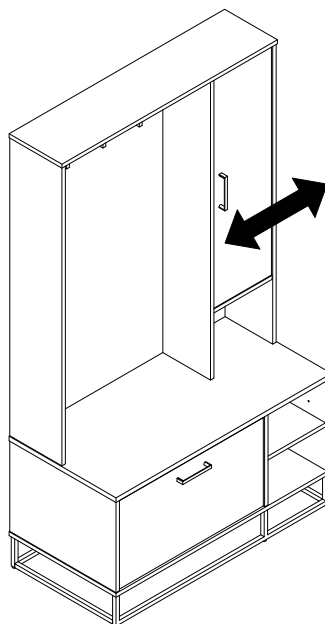
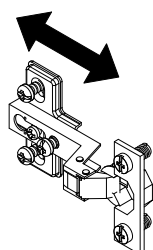
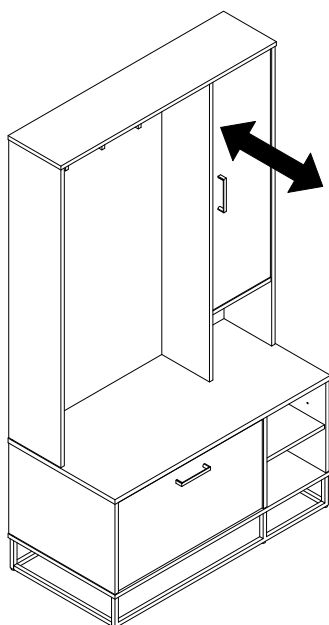
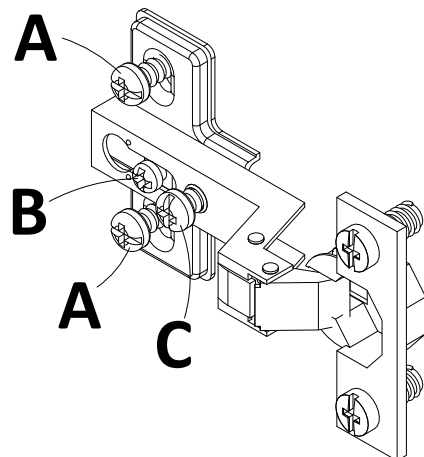

To adjust side to side:

Loosen the screw "C" on BOTH hinges and tighten "B" moves door outward. Loosen "B" and tighten "C" moves doors inward.

To adjust the depth:

Loosen the screw "B" and adjust door.

Maximum Loads

This unit has been designed to support the maximum loads shown. Exceeding these load limits could cause sagging, instability, product collapse, and/or serious injury.

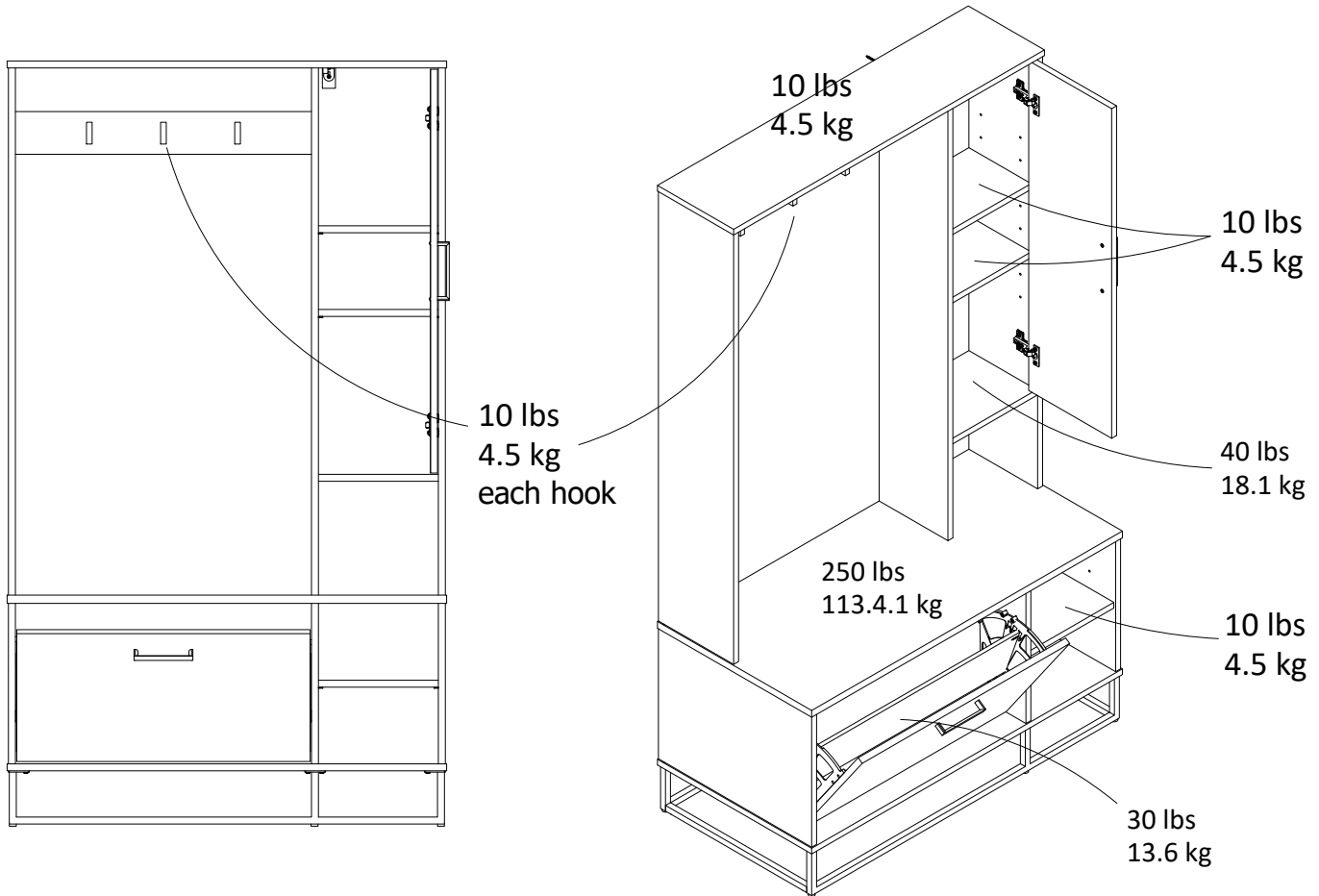

Warning: Risk of injury to persons - do not place a television on this furniture. This furniture is not approved for use with a television.

Certificate of Conformity

1. This certificate applies to the Dorel Home Furnishings, Inc. product identified by this instruction manual.
2. This certificate applies to compliance of this product with the CPSC Ban on Lead-Containing Paint (16 CFR 1303).
3. This product is distributed by: Dorel Home Furnishings, Inc.
410 East First Street South
Wright City, MO 63390
636-745-3351
4. Site of Manufacture: Tiffin OH
5. See front page of instruction manual for date of manufacture.

Register your product to receive the following:



- * New trend details - sneak peek on what's new
- * Surveys - have a voice within our community
- * Exclusive deals and discount codes
- * Quick and easy replacement part service

To register your product, visit ameriwoodhome.com

5 Star Rating



Visit your local retailer's website, rate your purchased product and leave us some feedback!

We would like to extend a big "Thank You" to all of our customers for taking the time to assemble this Ameriwood Home product, and to give us your valuable feedback.

*Thank
You!*

Español

Cubierta Delantera

Este libro de instrucciones contiene información **IMPORTANTE** de seguridad. Por favor lea y manténgalo para referencia en el futuro.

No Regrese este producto! Comuníquese con nuestro amistoso equipo de servicio al cliente para obtener ayuda.

Llámenos al: 1-800-489-3351 (Gratis) Lunes - Viernes 9am - 5pm CST

Visitar: www.ameriwoodhome.com

PRECAUCION

Este mueble puede volcarse y causar graves heridas y/o muerte.

Anclar el mueble a un poste de madera en la pared (si esto se requiere).

No Permita que los niños monten el mueble.

Mantenga los artículos más pesados en los cajones de abajo.

Consejos Útiles (página 2)

- Abra su artículo en el área donde usted planea utilizarlo para evitar levantar y moverlo menos
- Identificar, ordenar y contar las piezas antes de intentar ensamblar
- Las clavijas de compresión se golpean con un martillo
- Las diapositivas están marcadas con una R (derecha) y L (izquierda) para la colocación correcta
- Asegúrese de que siempre este el punto localizado en la parte superior de bloqueador de leva este volteado hacia borde exterior
- Utilizar todos los clavos para el panel de atrás y distribuirlos por igual
- El panel de atrás debe utilizarse para asegurarse de que la unidad quede fija y firme
- No use químicas fuertes ni limpiadores abrasivos en este artículo
- Nunca empuje, tire ni arrastre los muebles

Antes de Que Empieces (página 3)

- Lea cuidadosamente cada paso y siga el orden correcto
- Separar y contar todas sus piezas y hardware
- Dése suficiente espacio para el proceso de ensamble
- Tenga las siguientes herramientas: destornillador de cabeza plana, #2 cabeza Phillips
Destornillador y martillo
- Precaución: Si usa un taladro electrónico o un destornillador eléctrico para atornillar, por favor asegúrese que deje de atornillar cuando el tornillo este apretado. Fallar hacer esto puede causar barrer el tornillo.

Sistema de fijar el bloqueo de leva (página 3)

Este sistema de fijar el bloqueo de leva sera usado en todo el proceso ensamble.

Página 19

¡IMPORTANTE! EL PANEL TRASERO ES UNA PARTE ESTRUCTURAL DE ESTA UNIDAD Y DEBE INSTALARSE CORRECTAMENTE.

Despliegue el panel trasero. Con la superficie acabada hacia arriba, deslice el panel trasero en la ranura de los paneles superior izquierdo y superior derecho (A y B) asentándolo en la ranura de la parte superior (C). Tenga en cuenta que el panel trasero quedará sobre los soportes.

Página 26

¡IMPORTANTE! EL PANEL TRASERO ES UNA PARTE ESTRUCTURAL DE ESTA UNIDAD Y DEBE INSTALARSE CORRECTAMENTE.

Despliegue el panel trasero. Con la superficie acabada hacia arriba, deslice el panel trasero en la ranura de los paneles inferior izquierdo e inferior derecho (I y J) asentándolo en la ranura de la balda central (K).

Página 28

Coloque la cuña en los paneles traseros y deslice el labio en la ranura.
Apriete el tornillo para fijarlo en su sitio.

Página 31

Para mampostería, hormigón u otros materiales de pared:

Consulte en su ferretería local los anclajes adecuados para fijar firmemente el soporte de seguridad.

¡IMPORTANTE: ESTA UNIDAD DEBE FIJARSE A LA PARED PARA EVITAR QUE VUELQUE. SIGA ESTAS INSTRUCCIONES PARA INSTALAR EL SOPORTE DE SEGURIDAD ANTIVUELCO SUMINISTRADO CON ESTE PRODUCTO.

ADVERTENCIA

El vuelco de los muebles puede provocar lesiones por aplastamiento graves o mortales.

Para evitar el vuelco:

- * Instale el sistema de retención antivuelco proporcionado
- * Coloque los objetos más pesados en los cajones más bajos
- * A menos que esté específicamente diseñado para ello, no coloque televisores u otros objetos pesados en la parte superior de este producto
- * Nunca permita que los niños trepen o se cuelguen de los cajones, la puerta o los estantes
- * Nunca abra más de un cajón a la vez

El uso de sistemas de retención antivuelco solo puede reducir, pero no eliminar, el riesgo de vuelco

OPCIÓN 1: Fijación en un montante de la pared (método preferido)

Utilizando un localizador de montantes, localice un montante en la pared. Coloque su unidad contra la pared, con el soporte de seguridad alineado en esta ubicación. Para facilitar la introducción del tornillo, puede taladrar un orificio piloto de 1/8 de pulgada de diámetro (3 mm) a través del soporte de seguridad en el montante. Introduzca el tornillo a través del soporte de seguridad en el montante de la pared. Apriete el tornillo que no se apretó del todo en el paso 1.

OPCIÓN 2: Fijación en tabiquería seca

Ubique su unidad donde desee contra una pared y marque la pared a través del soporte de seguridad, luego mueva su unidad a un lado. Taladre un agujero de 3/16 de pulgada de diámetro (5 mm) en el tablero de la pared. Golpee el anclaje de pared en el agujero hasta que quede enrasado. Mueva su unidad a su ubicación y fije el soporte de pared al anclaje de pared con el tornillo. Apriete el tornillo que no se apretó del todo en el paso 1.

Página 35

Coloque el conjunto del cubículo para zapatos como se muestra.

Coloque los casquillos interiores en los casquillos exteriores que se insertaron en el panel inferior izquierdo (I) y en el tabique inferior (L).

Página 37

Puede hacer más grande una mitad de la abertura de la zapata retirando los dos tornillos que sujetan el panel central de la zapata (Q) y recolocándolo en el espacio delantero o trasero y volviendo a sujetar los dos tornillos.

Página 41

Ajuste de la puerta

Para ajustar la altura vertical

Afloje los tornillos "A" de ambas bisagras. Suelen estar en agujeros ranurados que le permiten ajustar unos mm hacia arriba o hacia abajo. A continuación, vuelva a apretarlos.

Para ajustar la profundidad:

Afloje el tornillo "B" y ajuste la puerta.

Para ajustar de lado a lado:

Afloje el tornillo "C" de AMBAS bisagras y apriete el "B" mueve la puerta hacia fuera. Afloje "B" y apriete "C" mueve la puerta hacia dentro.

Español

Página 42

CARGA MAXIMA

Esta unidad se ha diseñado para soportar las cargas máximas indicadas. Si se superan estos límites de carga se podría producir pandeo, inestabilidad, colapso del producto o lesiones graves.

Advertencia: Riesgo de lesiones a las personas; no coloque un televisor sobre este mueble. Este mueble no está homologado para su uso con un televisor.

Página 43

Registre su producto para recibir lo siguiente:

- * Detalles de nuevas tendencias - Vistazo a lo nuevo
- * Encuestas - alec su voz entre su comunidad
- * Códigos de ofertas y descuentos exclusivos
- * Fácil y rápido servicio de partes de remplace

Para registrar su producto, visite ameriwoodhome.com

Clasificación de 5 estrellas

Visite el sitio web de su tienda local, califique su comprado y denos sus comentarios!

Nos gustaría enviar un gran "Agradecimiento" a todos nuestros clientes por tomarse el tiempo de ensamblar este producto de Ameriwood Home, y por darnos sus valiosos comentarios.

Gracias

Français

Couverture Avant

CE LIVRET D'INSTRUCTION CONTIENT DES INFORMATIONS **IMPORTANTES** SUR LA SÉCURITÉ. VEUILLEZ LIRE ET GARDER POUR UNE RÉFÉRENCE FUTURE

Ne retournez pas ce produit! Contactez notre équipe de service à la clientèle amicale d'abord pour obtenir de l'aide.

Appelez-nous: 1-800-489-3351 (sans frais) du Lundi au Vendredi de 9h à 17h Heure Centrale

Visitez: www.ameriwoodhome.com

ATTENTION

Le meuble peut basculer et causer des blessures graves ou la mort.

Ancrer le meuble à une planche murale dans le mur (si indiqué).

Ne laissez pas les enfants grimper sur le meuble.

Placez les articles lourds sur les étagères ou dans les tiroirs inférieurs.

Astuces Utiles (page 2)

-Ouvrez votre article dans la zone que vous prévoyez de le garder pour moins de levage lourd

-Identifier, trier et compter les pièces avant d'essayer d'assembler

-Les goujons de compression sont taraudés avec un Marteau

-Les glissières sont marquées d'un R (droit) et d'un L (gauche) pour un bon placement

-Assurez-vous toujours de faire face la pointe situé sur le haut de la Serrure de Came vers le bord extérieur

-Utiliser tous les clous fournis pour le panneau arrière et les répartir également

-Le panneau arrière doit être utilisé pour vous assurer que votre appareil est robuste

-N'utilisez pas de produits chimiques agressifs ou de nettoyeurs abrasifs sur cet appareil

-Ne jamais pousser, tirer, ou faire glisser votre meuble

Avant de Commencer (page 3)

-Lisez attentivement chaque étape et suivez le bon ordre

-Séparez et comptez toutes vos pièces et matériaux

-Donnez-vous suffisamment de place pour l'assemblage

-Avoir les outils suivants: tournevis à tête plate, #2 tournevis Phillips, et Marteau

-Attention: Si vous utilisez une perceuse électrique ou un tournevis électrique pour visser, veillez à ralentir et arrêter lorsque la vis est bien serrée. Le non-respect de cette consigne peut endommager la vis.

Système de Fixation de Came (page 3)

Ce Système de Fixation de Came sera utilisé tout au long de l'assemblage

Français

Page 19

IMPORTANT! LE PANNEAU ARRIÈRE EST UN ÉLÉMENT STRUCTUREL DE L'APPAREIL ET DOIT ÊTRE INSTALLÉ CORRECTEMENT.

Dépliez le panneau arrière. En orientant la surface finie vers le haut, faites glisser le panneau arrière dans la rainure des panneaux supérieur gauche et supérieur droit (A et B) en l'insérant dans la rainure de la partie supérieure (C). Notez que le panneau arrière se trouve au-dessus des supports.

Page 26

IMPORTANT! LE PANNEAU ARRIÈRE EST UN ÉLÉMENT STRUCTUREL DE L'APPAREIL ET DOIT ÊTRE INSTALLÉ CORRECTEMENT.

Dépliez le panneau arrière. En orientant la surface finie vers le haut, faites glisser le panneau arrière dans la rainure des panneaux inférieur gauche et inférieur droit (I et J) en l'insérant dans la rainure de l'étagère centrale (K).

Page 28

Positionnez la cale sur les panneaux arrière et faites glisser la lèvre dans la rainure. Serrez la vis pour la bloquer en place.

Page 31

Pour la maçonnerie, le béton ou d'autres matériaux muraux :

Consultez votre quincaillerie locale pour obtenir les ancrages appropriés afin de fixer solidement le support de sécurité.

IMPORTANT : CET APPAREIL DOIT ÊTRE FIXÉ AU MUR POUR ÉVITER QU'IL NE BASCULE. SUIVEZ CES INSTRUCTIONS POUR INSTALLER LE SUPPORT DE SÉCURITÉ ANTI-BASCULEMENT FOURNI AVEC CE PRODUIT.

AVERTISSEMENT

Le basculement d'un meuble peut entraîner des blessures graves, voire mortelles, par écrasement.

Pour éviter le basculement :

- * Installez les dispositifs de retenue en cas de basculement prévus.
- * Placez les objets les plus lourds dans les tiroirs les plus bas.
- * Ne placez pas de téléviseurs ou d'autres objets lourds sur le dessus de ce produit, sauf s'il est spécifiquement conçu pour les accueillir.
- * Ne laissez jamais les enfants grimper ou se suspendre aux tiroirs, à la porte ou aux étagères.
- * N'ouvrez jamais plus d'un tiroir à la fois.

L'utilisation de dispositifs de retenue en cas de basculement ne peut que réduire, mais non éliminer, le risque de basculement

OPTION 1 : Fixation dans un montant mural (méthode préférée)

À l'aide d'un détecteur de montants, positionnez un montant dans le mur. Placez votre appareil contre le mur, le support de sécurité étant aligné sur cette position. Pour faciliter l'enfoncement de la vis, vous pouvez percer un avant-trou de 3 mm de diamètre à travers le support de sécurité dans le montant. Enfoncez la vis à travers le support de sécurité dans le montant du mur. Serrez la vis qui n'a pas été complètement serrée à l'étape 1.

OPTION 2 : Fixation dans les cloisons sèches

Positionnez votre appareil à l'endroit souhaité contre un mur et marquez le mur à travers le support de sécurité, puis mettez votre appareil de côté. Percez un trou de 3/16 de pouce de diamètre (5 mm) dans le panneau mural. Tapez la cheville dans le trou jusqu'à ce qu'elle soit à fleur. Mettez votre appareil en position et fixez le support mural à l'ancrage mural à l'aide de la vis. Serrez la vis qui n'a pas été complètement serrée à l'étape 1.

Page 35

Positionnez l'ensemble du casier à chaussures comme indiqué.

Placez les bagues intérieures dans les bagues extérieures qui ont été insérées sur le panneau inférieur gauche (I) et la cloison inférieure (L).

Page 37

Vous pouvez agrandir une moitié de l'ouverture de la chaussure en retirant les deux vis qui fixent le panneau central de la chaussure (Q) et en le repositionnant dans l'espace avant ou arrière et en fixant à nouveau les deux vis.

Page 41

Ajustement de la porte

Pour ajuster la hauteur verticale :

Desserrez les vis « A » des deux charnières. Elles se trouvent généralement dans des trous oblongs, ce qui vous permet de les ajuster de quelques mm vers le haut ou vers le bas. Resserrez ensuite.

Pour ajuster la profondeur :

Desserrez la vis « B » et ajustez la porte.

Pour ajuster la porte d'un côté à l'autre :

Desserrez la vis « C » sur les DEUX charnières et serrez « B » pour déplacer la porte vers l'extérieur.

Desserrez la vis « B » et serrez la vis « C » pour déplacer les portes vers l'intérieur.

Français

Page 42

Charges maximales

Cet appareil a été conçu pour supporter les charges maximales indiquées. Le dépassement de ces limites de charge peut entraîner un affaissement, une instabilité, un effondrement du produit ou des blessures graves.

Avertissement : Risque de blessure pour les personnes; ne placez pas de téléviseur sur ce meuble. Ce meuble n'est pas homologué pour recevoir un téléviseur.

Page 43

Enregistrez votre produit pour recevoir les éléments suivantes:

- * Détails sur les nouvelles tendances - un aperçu sur les nouveautés
- * Sondages - avoir une voix au sein de notre communauté
- * Offres exclusives et codes promo
- * Service de pièces de rechange rapide et facile

Pour enregistrer votre produit, visitez ameriwoodhome.com

5 Étoiles

Visitez le site Web de votre détaillant local, évaluez votre produit acheté et laissez-nous quelques commentaires !

Nous tenons à offrir un grand "Merci" à tous nos clients pour avoir pris le temps d'assembler ce produit "Ameriwood Home", et de nous donner vos commentaires précieux.

Merci